

Summer 2016

Development of the Compact Jet Engine Simulator from Concept to Useful Test Rig

Henry H. Haskin
Old Dominion University

Follow this and additional works at: https://digitalcommons.odu.edu/mae_etds

 Part of the [Acoustics, Dynamics, and Controls Commons](#), and the [Aerospace Engineering Commons](#)

Recommended Citation

Haskin, Henry H.. "Development of the Compact Jet Engine Simulator from Concept to Useful Test Rig" (2016). Master of Science (MS), thesis, Mechanical & Aerospace Engineering, Old Dominion University, DOI: 10.25777/hrhy-a104
https://digitalcommons.odu.edu/mae_etds/14

This Thesis is brought to you for free and open access by the Mechanical & Aerospace Engineering at ODU Digital Commons. It has been accepted for inclusion in Mechanical & Aerospace Engineering Theses & Dissertations by an authorized administrator of ODU Digital Commons. For more information, please contact digitalcommons@odu.edu.

DEVELOPMENT OF THE COMPACT JET ENGINE SIMULATOR FROM CONCEPT TO USEFUL TEST RIG

By

Henry H. Haskin

B.S. March 1979, Virginia Polytechnic Institute and State University

A thesis Submitted to the Faculty of Old Dominion University in Partial Fulfillment of the
Requirements for the Degree of

MASTER OF SCIENCE IN AEROSPACE ENGINEERING

OLD DOMINION UNIVERSITY

August 2016

Approved by:

Arthur Taylor (Director)

Robert Ash (Member)

Michael Doty (Member)

ABSTRACT

DEVELOPMENT OF THE COMPACT JET ENGINE SIMULATOR FROM CONCEPT TO USEFUL TEST RIG

Henry H. Haskin

Old Dominion University, 2016

Director: Dr. Arthur Taylor

Two Compact Jet Engine Simulator (CJES) units were designed for integrated wind tunnel acoustic experiments involving a Hybrid Wing Body (HWB) vehicle. To meet the 5.8% scale of the HWB model, Ultra Compact Combustor technology from the Air Force Research Laboratory was used. The CJES units were built and integrated with a control system in the NASA Langley Low Speed Aeroacoustic Wind Tunnel. The combustor liners, plug—vane and flow conditioner components were built in-house at Langley Research Center. The operation of the CJES units was mapped and fixes found for combustor instability tones and rig flow noise. The original concept remained true, but the internal hardware evolved throughout the process. The CJES units successfully completed the HWB validation test and can be used for acoustic testing or propulsion integration studies that require jet engines.

ACKNOWLEDGEMENTS

There are many people who have contributed to the successful completion of this work. I extend many thanks to my committee members for their patience and hours of editing this manuscript.

The author sincerely thanks the Environmentally Responsible Aviation Project for funding this work. The efforts of the Jet Noise Lab technical staff (John Swartzbaugh, Shaun Reno, Clint Reese, Butch Allen, and Mike Carr) are gratefully acknowledged. Additionally, the authors thank Les Yeh, Mark Carpenter, and Mike Henshaw for CJES control implementation, Robert Andrews, Michael Powers and Mark Griffith for their support in additive manufacturing and ceramics, and Governor's School student Megan Beisser for her assistance in the swirl velocity measurements. Lastly, the authors acknowledge the excellent support of the NASA Langley Research Center fabrication and welding services, as well as the welding services of Bill Clemens at the Thomas Jefferson National Accelerator Facility.

I have to give special credit and thanks to my wife, Betty Haskin for putting up with me during this process. I would not have finished this program without her support.

Nomenclature

AFRL	Air Force Research Laboratory
CAEP	Committee on Aviation Environmental Protection (part of ICAO)
CJES	Compact Jet Engine Simulator
ERA	Environmentally Responsible Aviation
FAA	Federal Aviation Administration
HWB	Hybrid Wing Body
ICAO	International Civil Aviation Organization
JES	Jet Engine Simulator
MIT	Massachusetts Institute of Technology
Mwt	Mach Number Wind Tunnel
NACA	National Advisory Committee on Aeronautics
NASA	National Aeronautics and Space Administration
NPR	Nozzle Pressure Ratio
NTR	Nozzle Temperature Ratio
UCI	University of California Irvine
UTRC	United Technologies Research Corporation

TABLE OF CONTENTS

LIST OF FIGURES	viii
I. Overview	1
II. Literature Search	3
III. General Arrangement Changes	7
IV. Implementation of AFRL Concept	9
V. Swirl Air and Flow Conditioner Study	11
VI. Final Design/Build Contract	12
VII. Ceramic Combustor Liner and Plug-Vane Development	13
VIII. Direct Metal Laser Sintered Fabrication	19
IX. Initial Testing of the CJES	24
X. Combustion Instability Issue	35
XI. Rig Noise Reduction	39
XII. Results Summary	42
XIII. Conclusions	44
XIV. Future Work	38
BIBLIOGRAPHY	49
APPENDICES	
A Variations of the CJES and HWB during Development	52
B Infrastructure to Support HWB Acoustic Test	60
VITA	65

List of Figures

- Figure 1 The 14x22' Subsonic Wind Tunnel Test Section Configured for the HWB test.
- Figure -2 The Effect of Flame Impingement on a Flow Conditioner.
- Figure 3 The Effect of Flame Impingement on a Temperature Rake.
- Figure 4. Two Versions of Trapped Vortex Combustors
- Figure 5. Schematic Axial View of UCC (on left) and Side View
- Figure 6. Boeing Concept of the Hybrid Wing Body Aircraft
- Figure 7. The Compact Jet Engine Simulator
- Figure 8 Swirl Air Configuration of the CJES Combustor.
- Figure 9 Comparison of Air and Fuel Supplies between CJES and AFRL's UCC/ITB
- Figure 10 Swirl Air Valve Calibration Test and Data.
- Figure 11 Views of the Combustor Liner Showing Features to be Cast
- Figure 12 First Combustor Mold Version
- Figure 13 Wax Core Insert Cutting Fixture and a Wax Core
- Figure 14 Failed Ceramic Combustor Liners, New Coarse Material on the left, and New Fine Material on the right
- Figure 15 Ceramic Plug-Vane Mold Details
- Figure 16 DMLS Failed Fan Flow Conditioners and Core Flow Conditioner
- Figure 17 DMLS Combustor Liner on the CNC Lathe
- Figure 18 A Finished CoCr Combustor Liner
- Figure 19 DMLS Plug-Vane Parts. The build on the left failed due to support failure then deflection. On the right is a batch of four units with CAD generated supports.
- Figure 20 Initial testing Configuration of CJES Combustor in the Jet Noise Laboratory
- Figure 21 CJES First Light (a) and Combustion in the Annulus (b) a Faint Blue Glow, Combustion in the Annulus from Aft Camera (c).
- Figure 22 Angular Velocity Probe Installed in Glow Plug Port (upper left), Modified Combustor Liner with Larger Swirl Nozzles (upper right), Probe Details (lower photographs)
- Figure 23 Swirl Air Velocity in the Combustor Annulus
- Figure 24 Froude Number for Cracked and New Combustor Liners.

- Figure 25 Propane Injector Modifications; Pressure Dropping Screen (a), Diverter Loop (b), Cross Drilled (c).
- Figure 26 Combustion Switching Outside of the Annulus
- Figure 27 Soot Buildup in the CJES Unit after First Flow Conditioner Run
- Figure 28 Failure of the Sintered Screen Flow Conditioner.
- Figure 29 Combustor Liner after first Flow Conditioner Failure showing Soot Structures
- Figure 30 Second Screen Flow Conditioner Failure
- Figure 31 Section View of CJES with Alternate Fan Flow Conditioner and Fan Plenum Diverter.
- Figure 32 Comparison of Flow Conditioners in CJES Fan Stream
- Figure 33 Combustion Driven Tones in the Core ~ 25dB Above Broadband Levels
- Figure 34 Some of the Combustor Change Variations tried to eliminate the Combustor Instability
- Figure 35 Schematic UCC including nonuniform downstream flow conditioner and perforated screen upstream flow conditioner used together to eliminate combustion instability tones²⁴. Elimination of Combustion Tones (left)
- Figure 36 Hybrid Wing Body Model in 14x22' Tunnel with the CJES Units and Model Support
- Figure 37 Thermal Stress Cracks and Oxidation of Plug-Vane after 35 hours of Operations.
- Figure 38 Cobalt Chrome Combustor Liner After initial Testing. Pictures a, b are after 6 hours testing. Pictures c, d are after 30 hours testing. Pictures e, f and g are after 50 hours of testing.
- Figure 39 Far-field one-third octave acoustic spectra with CJES and LSAF operating at nominal original cutback condition: $NPR_{core}=1.285$, $NPR_{fan}=1.508$, $NTR_{core}=2.792$, $NTR_{fan}=1.135$, $Mwt = 0.10$.
- Figure 40 Far-field acoustic spectra with axisymmetric nozzles and CJES operating at updated cutback condition: $NPR_{core}=1.240$, $NPR_{fan}=1.461$, $NTR_{core}=2.721$, $NTR_{fan}=1.124$, $Mwt = 0.10$ showing a) spectral and b) directivity differences between CJES units.
- Figure 41 Core Flow Conditioners showing Nonuniform Heating. Pictures A and B show upstream and downstream view of the same part.
- Figure 42 Combustor Modified for Pressure Taps and Axial View with a Flow Conditioner.

Overview

NASA in cooperation with Industry and other governmental agencies developed a Technology roadmap to improve future aircraft designs. To support the 2020 Initial Operational Capability goal (N+2) Environmentally Responsible Aviation (ERA), Integrated Systems Research Program²⁸ was funded to develop an aircraft design and tools to evaluate the design's performance in four key areas²⁹: noise – 42dB below FAA Stage 4, NOx Emissions -75% (below CAEP 6), Aircraft fuel burn -40%, Runway length -50%. All of these relative to a B777/GE90 configuration. Boeing Phantom Works, MIT Gas Turbine Lab, UCI Mechanical and Aerospace Engineering Department, United Technologies' Pratt & Whitney UTRC and NASA joined together to develop new design tools, a wind tunnel model and a validation test. This thesis work was part of the risk reduction efforts to provide test hardware for the validation data. The Compact Jet Engine Simulator would provide the hot gas streams required to simulate the jet engines of a 5.8% scale model in the NASA Langley Research Center's 14x22' Subsonic Wind Tunnel. The Wind Tunnel Model was derived from the Cambridge-MIT Institute SAX-40 design by Boeing in a nonproprietary configuration called the Hybrid Wing Body (HWB).

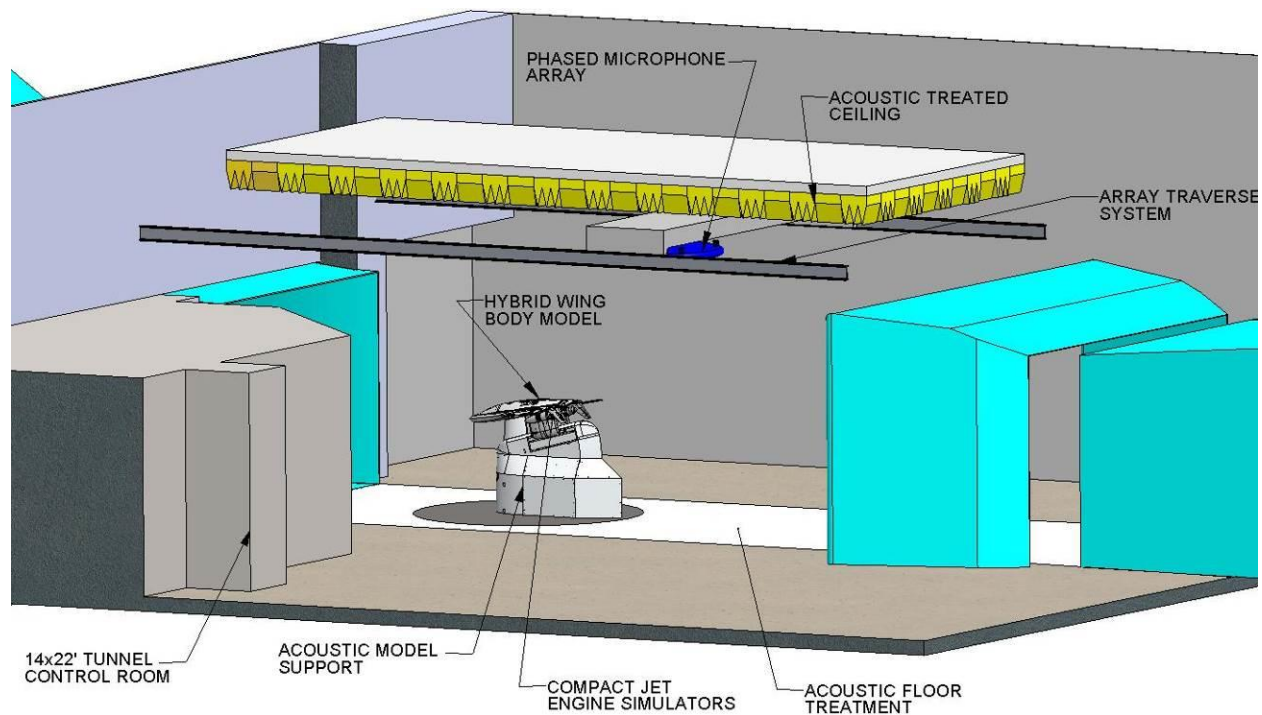

Figure 1 The 14x22' Subsonic Wind Tunnel Test Section Configured for the HWB test.

The Compact Jet Engine Simulator (CJES) was to be able to simulate subsonic transport jet engines from a bypass ratio of 5:1 to 15:1. As the aircraft model design progressed through many iterations, it became clear that a bypass ratio of 10:1 would be used for the N+2 configuration and the CJES design was capped at that high end bypass ratio because the nacelle for a larger nozzle would interfere with the model fuselage. The goal was to build a dual stream hot gas generator for nozzle testing that was roughly 1/3 the size of the “state of the art” rigs. The already developed rigs were 8 to 9 feet long and were about the same length as the entire model. The blockage effects of those rigs would ruin the flow over the model and invalidate the test data.

The engine data came from NASA Glenn Research Center’s engine performance program and the take-off conditions are shown in the table below. The red highlighted items became the sizing conditions for the CJES.

	BPR-15		BPR-10		BPR-5	
	Mass Flow (#/s)	Temp (°F)	Mass Flow (#/s)	Temp (°F)	Mass Flow (#/s)	Temp (°F)
Fan	12.25	90	7.10	130	5.793	150
Core	0.842	960	0.70	1047	1.225	1510

Table 1. Sizing Mass Flows and Temperatures for the CJES Design

The initial concept was to copy elements from the large Jet Engine Simulator in the Low Speed Aeroacoustic Wind Tunnel using one burner for the core stream. The first goal would be to shorten the flame length at the maximum flow condition. Due to the model scale, the duct sizes would be limited and the air velocity higher than desired. In the JES at high air mass flows the flame would be stretched because the air velocity exceeded the flame speed. In the core stream, flame impingement has occurred 13 feet downstream of the burner. This condition caused flame impingement on flow conditioners and the instrumentation with the resulting loss of the probes. This is also the reason that the “state of the art” rigs were 3 to 4 times longer than usable in this test.

The initial design was proposed to the team and the other aspects of the aircraft design progressed. In addition the design for the needed infrastructure to operate burners safely in the wind tunnel began. Major concerns were where to locate the propane storage and run tanks, the nitrogen purge bottle trailer and an outside test stand for operator training and certification. The use of national standards and safety concerns directed many of the design choices for the facility and the CJES.

A conventional dump or sudden expansion burner design was developed in parallel with a literature search for more compact combustor concepts. The initial concepts for the CJES were based on a dump combustor and turbulence generating devices. The first series of variations used a premixed fuel air concept of an off the shelf burner from a Navy project. Calculation of the heating required for the Hybrid Wing Body test conditions revealed that the low temperatures could not be met with a premixed configuration. The highest test temperature resulted in air – fuel ratios well below the flammability limit so fuel injection at the sudden expansion was necessary. This finding would actually play a critical part in simplifying the overall system design. The Fire Chief did not require an active fire suppression system be included in the facility because of the self-extinguishing capability of the combustor.

Literature Search

Many papers dating back to the 1950s are available on combustor designs. The archive of NACA technical papers is a rich source of information. For the high flow rates in the CJES, fully turbulent flames are to be expected. Most turbulent combustors use variations on the basic sudden expansion flame holding technique. The fuel is introduced into the incoming air stream a short distance ahead of a step increase in the duct size. The aft facing step creates a flow recirculation region that holds the flame front and enhances the fuel mixing for better combustion. Slotted can burners and perforated shell burners are variations of the simple step expansion. Jet engine after burners inject the fuel ahead of a V shaped flame holder gutter^(1, 2) in another variation.

The large flow rig in the NASA Low Speed Aeroacoustic Wind Tunnel (LSAWT) uses Sudden Expansion Burners from the Mardquart Co. These units are rated to supply 20 pounds/second of air at 3000°F. They have been in service since 1994 and have provided most of the combustor experience for the author. The stretching of the flame due to high velocity flow and flame impingement problems have been due to these burners. To provide clean flow to a nozzle for acoustic testing, one needs to supply uniform temperature and pressure flow to the nozzle. The best way to achieve that is with a pressure dropping flow conditioner. At the LSAWT brazed corrugated and wound foil flow conditioners have

worked the best. On the right below is a picture of a new flow conditioner. On the left is a flow conditioner with about 200 hours of use. The parts are made of nickel super alloy foil that is nickel brazed together. One can see on the left the foil has slipped and the corrugations are no longer uniform (creep of the braze joints). The heat exposed unit would shed flakes of oxidized metal when squeezed by hand. Also the loss of material in the center of the picture is evident.



Figure -2 The Effect of Flame Impingement on a Flow Conditioner.



Figure 3 The Effect of Flame Impingement on a Temperature Rake.

Flame impingement on instrumentation will also quickly end a test. To the left is a photograph of a thermocouple rake after a flame played across it (a < 5 second event). The Inconel sheathed thermocouples fared better than the pressure probe rakes. The pressure tubes all burned off. The flow conditioners and rakes were about 14 feet from the flame holding section of the sudden expansion burner in the LSAWT. In the Compact Jet Engine Simulator the flow conditioner will be 7.8 inches from the combustion section.

Many papers by the Air Force Aero Propulsion Laboratory are available on Dump combustors. These papers were produced to form a data base for scaling dump combustors for ramjet development⁽⁴⁻¹⁰⁾. With further research of the AFRL papers, it became evident that some other combustor type would be required to achieve the goal of shortening the combustor to an acceptable length.

Swirling flow combustion offers the required increase in flame speed to meet the CJES rig length goal. A paper by George D. Lewis⁽¹³⁾ documented a test of centrifugal loading on flame propagation in 1971. In a contractor report for the Air Force, Lewis found that the flame propagation speed could be increased by a factor of four or more⁽¹²⁾. The introduction of Lewis's contractor report describes the mechanism, "There are two commonly accepted means of spreading flame through a combustible mixture in practical combustion systems. The first of these, laminar flame propagation, depends on heat conduction and the diffusion of chemically active species into tile adjacent fuel-air mixture to propagate the fire. One foot per second is a typical laminar flame speed for stoichiometric hydrocarbon-air mixtures. The second, turbulent flame propagation, adds the turbulent transport of small elements of flame a short distance into the unburned mixture to act as new ignition sources. Turbulent flame speeds in hydrocarbon-air mixtures typically range from 2 to about 20 feet per second. In the past, when attempts have been made to increase tile turbulent flame speed to higher values, the pressure drop required to produce the turbulence has been prohibitive for practical applications, or flame stabilization problems prevented operation at higher velocities. Recently, tests in a combustion centrifuge have demonstrated that centrifugal force can be used to increase flame propagation rates by an additional factor of 4 or more." As part of the contractor study, a scale afterburner was built and tested. The testing results indicated that a full scale afterburner could be shortened by 1/3. This was additional confirmation that a high swirl combustor was the correct design direction.

Additional searching turned up a test facility at the Wright Patterson Air Field, Air Force Research Lab, and the Atmospheric-Pressure Combustion Research Complex (APCRC) that was doing research on the

application of Lewis's concept. The APCRC has been developing two types of combustors Trapped Vortex Combustion technology and an Ultra-Compact Combustor (UCC).

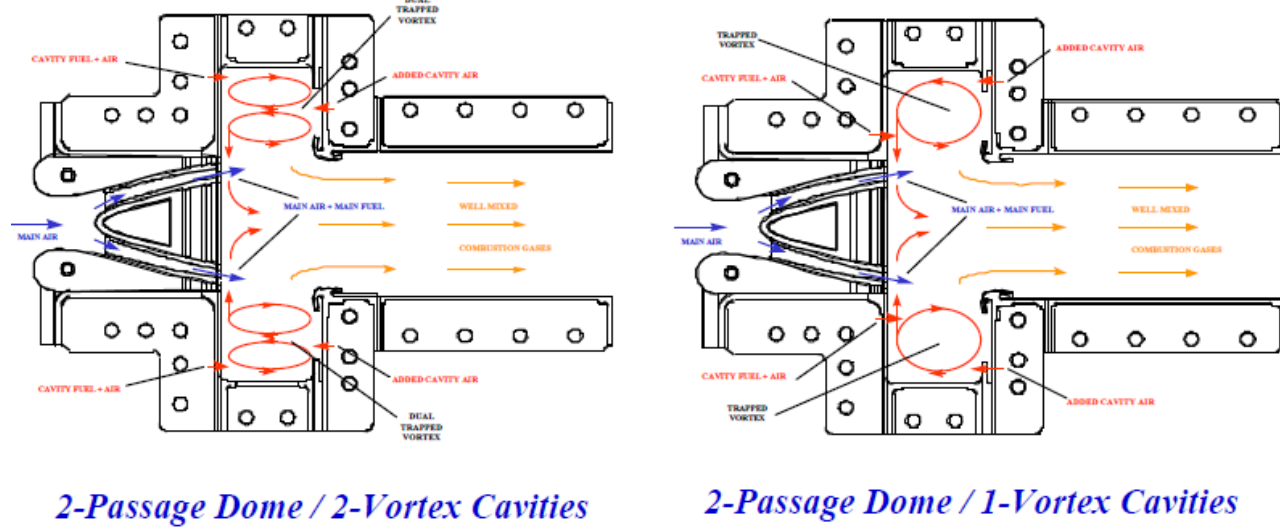

Figure 4. Two Versions of Trapped Vortex Combustors⁽¹⁴⁾

The Trapped Vortex Combustor, shown in Figure 2, provides improved combustion performance and reduced nitrogen oxides production, but is more complicated to build in the desired model size.

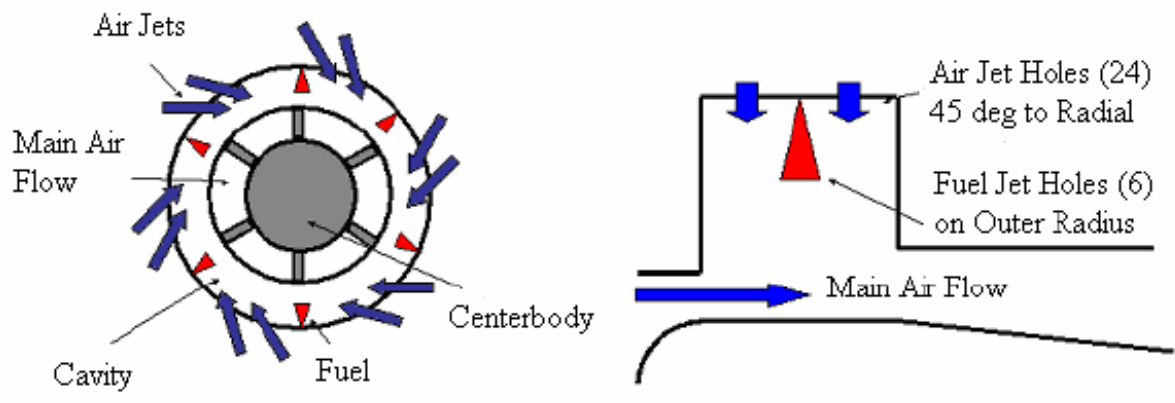

Figure 5. Schematic Axial View of UCC (on left) and Side View⁽¹⁵⁾

The Ultra Compact Combustor, shown in Figure 5, has the advantages of the Trapped Vortex Combustor and the combustion occurs mainly in the annular passage. The combustion air fuel mixture is swirled around the main air flow to generate high centrifugal loading and provide residence time for the flame without adding axial length. The original UCC was developed at the Atmospheric-Pressure Combustion Research Complex, part of the Air Force Research Laboratory at Wright –Patterson Air Force Base. The original versions of the UCC were close in size to that required for the HWB test rig. A preliminary design was developed and sent to Joseph Zelina, the head of the APCRC. His comments were incorporated into the design.

General Arrangement Evolution

Flow rigs to test acoustic performance of jet nozzles are designed to minimize the impact of delivering the desired air flow to the nozzle. For the test to be relevant one has to match the air stream temperature & pressure ratios to that of the engine with the scaled mass flow rate. This applies to both the core and bypass air streams. If the model size does not matter one uses large duct sizes to minimize the flow noise and provide a large contraction ratio for good flow uniformity. This test the flow rig also had to be near the scale engine nacelle size. The free stream air flow over the fuselage/wing affects the mixing with the nozzle flow, so the large duct idea is not possible. The contraction ratio for the nozzles ended up matching typical engine nozzles. Flow conditioners, pressure dropping grids, were added to supply the flow uniformity and reduce rig flow noise. While the CJES design was under way the airframe geometry was changing as the engine location was being determined. The engines will be over the wing so the wing would shield the observer on the ground from noise. Part of the HWB design was to evaluate the shielding effects. The engine nacelle height above the fuselage and the distance from the trailing edge were varied. At one point in the design cycle the CJES would have to include a 20° bend to clear the fuselage. Fortunately, cross flow from the wing over the fuselage drove the nacelle height upward to minimize the flow separation at the nacelle inlet at takeoff and eliminated a supersonic separation bubble at cruise to allow an inline CJES design. Eventually the airframe design was frozen and the nacelle design was finalized in late 2009. The final model design is shown in Figure 6 below.

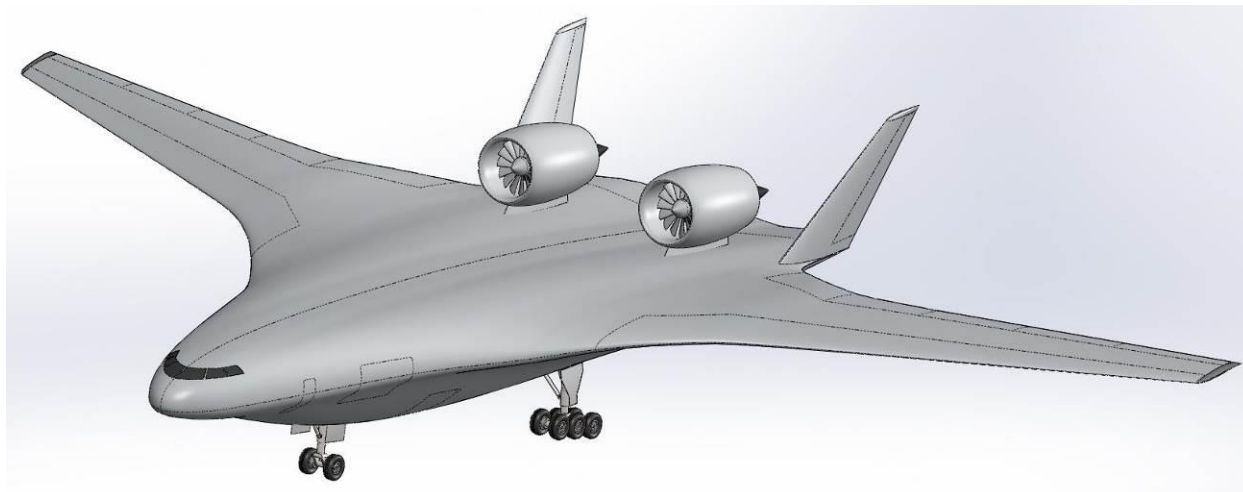

Figure 6. Boeing Concept of the Hybrid Wing Body Aircraft

The initial UCC design in the Compact Jet Engine Simulator brought the model nacelle size down to 1.5 times the scale nacelle length. Computational Fluid Dynamics (CFD) modeling showed a stagnation pressure bubble on the wing/body caused by the CJES nacelle which disturbed the flow over the wing. The nacelle was modified with a longer forward taper to eliminate the high surface pressures and the nacelle grew to be 1.8 times the scale engine nacelle length. The stagnation pressure rise was due to the fact that the CJES cannot ingest the incoming air flow like an engine, the front is closed off. The blunt nose stagnates the incoming flow and forces it around the nacelle. The longer nose provided better flow lines over the fuselage. The CJES configuration is shown in Figure 7 below.

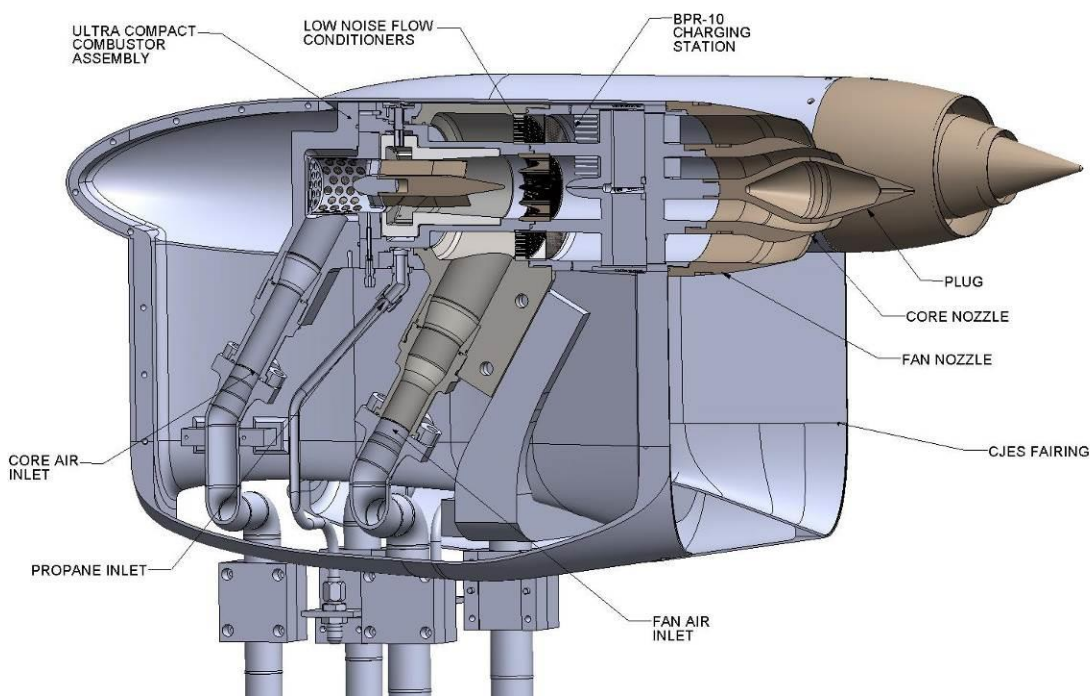

Figure 7. The Compact Jet Engine Simulator in Cross Section.

The final engine sizing also varied during the process and resulted in the values shown in Table 1. The scaled nacelle ended up being 8 inches on the outer diameter. Trying to achieve contraction ratios of 1.5 for both streams and keep the duct Mach number below 0.3 also proved to be challenging. The CJES units had to translate axially to study the shielding effect of the wing and integrate with the model support being supplied by another vendor. Several other changes to the AFRL design were needed to adapt the concept to NASA's application.

Implementation of the AFRL UCC Concept

The AFRL concept used a separate swirl air feed. This added another variable to the combustor control which is needed for combustor studies, but not for a space constrained wind tunnel model system. The swirl air for the CJES was provided by the main core air stream. A sintered screen flow conditioner supplied uniform flow into the main core air passage. Two annular ports fed air through manually set globe valves to the swirl air plenum around the combustor liner. The swirl air plenum also provided

cooling air to the highest temperature section of the combustor liner. The swirl air supply is shown in Figure 8 below.

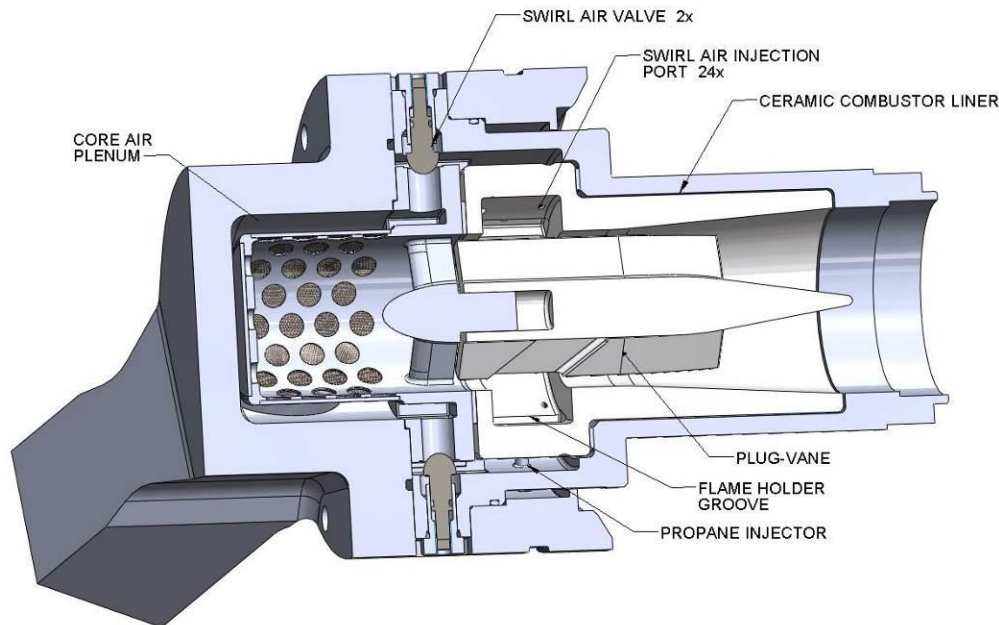

Figure 8 Swirl Air Configuration of the CJES Combustor.

The NASA UCC design would be using gaseous propane as the fuel instead of liquid jet fuel in the AFRL case. There are several safety reasons for this. With gaseous fuel, the supply can be cut off close to the combustor and purged if an emergency stop condition occurs. With liquid fuel the reaction time to safe the system is much longer (mass of fuel is larger) and some fuel remains trapped in the system. With gaseous propane the combustion has to occur in the combustor annulus. If combustion does not occur, then the main core flow mixes with the combustor flow and the resulting mixture is below the flammability limit for propane. With liquid jet fuel one could achieve a flammable mixture outside of the combustor or leave a fuel spill to clean up.

To achieve the design goal of an 8" outside diameter on the CJES fairing, the fuel and air supplied to the combustor had to be nested in coannular manifolds. Figure 9 below, shows a comparison of the CJES on

the left with the AFRL UCC/ Inter Turbine Burner (ITB) on the right. The CJES has an outer annular propane manifold with fuel injectors protruding radially into the combustor liner. Inside the propane manifold is the swirl air manifold. One can see the 12 of the 24 air injection ports that induce the swirl in the combustor annulus. The AFRL rig had separate fuel and air feeds which made studying the combustion process easier. Based on the results of the AFRL studies, the ratio of swirl air to main core air was known and the NASA design did not need the extra variables nor could they be fitted into the confined space available.

AFRL would not provide any drawings or dimensions of the configurations they tested other than what was published in open access papers. Using that data the Author picked sizes for the combustor annulus and worked them into the design. Joseph Zelina, from AFRL gave some general comments and sizing suggestions. With the third version Mr. Zelina said we were close to what they had tested so the internal geometry was frozen and the design proceeded. The plug in the CJES is about $\frac{1}{2}$ the diameter of the AFRL version⁽²⁰⁻²²⁾.

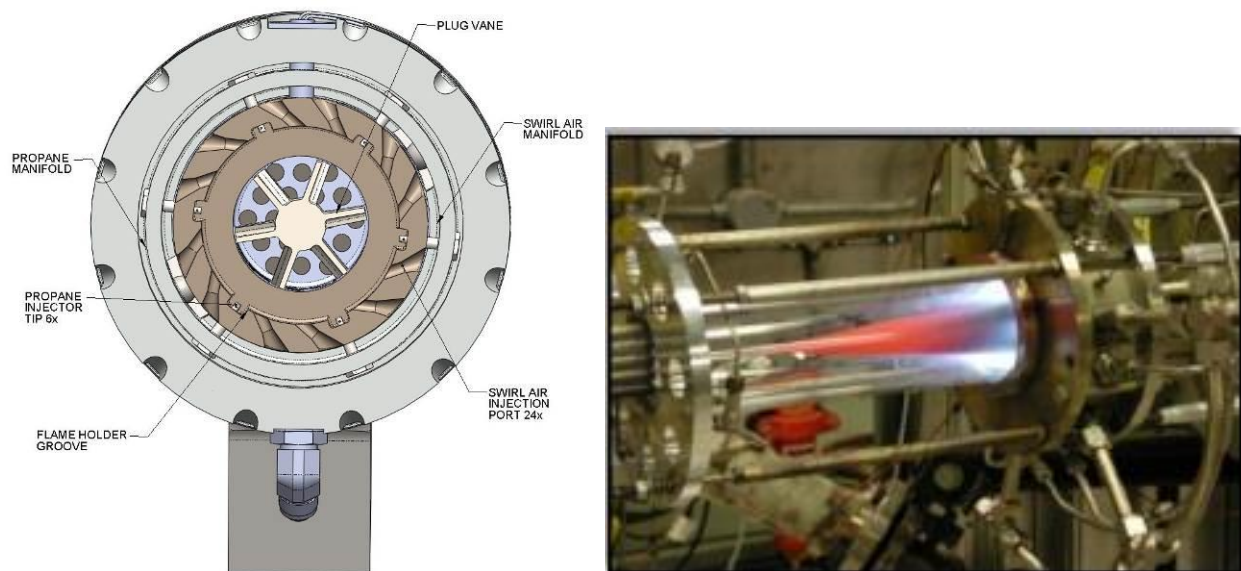

Figure 9 Comparison of Air and Fuel Supplies Between CJES and AFRL's UCC/ITB⁽¹⁷⁾.

Swirl Air and Flow Conditioner Study

To find a starting point for testing the CJES, the initial swirl air valve setting needed to be determined. A test was made in the Small Anechoic Jet Facility (SAJF) to simulate the swirl air valve conditions. The test rig for studying flow conditioners was modified by adding a flanged Swirl Air Valve Calibration Rig into the flow Conditioner Test hardware (see Figure 10). With this setup we could evaluate the inlet flow conditioner and determine the initial valve setting to obtain 14.5% of the core flow going through the swirl air nozzles. For 14.5% of the core air to flow through the swirl air nozzles we needed to start at 2.75 turns of the valve.

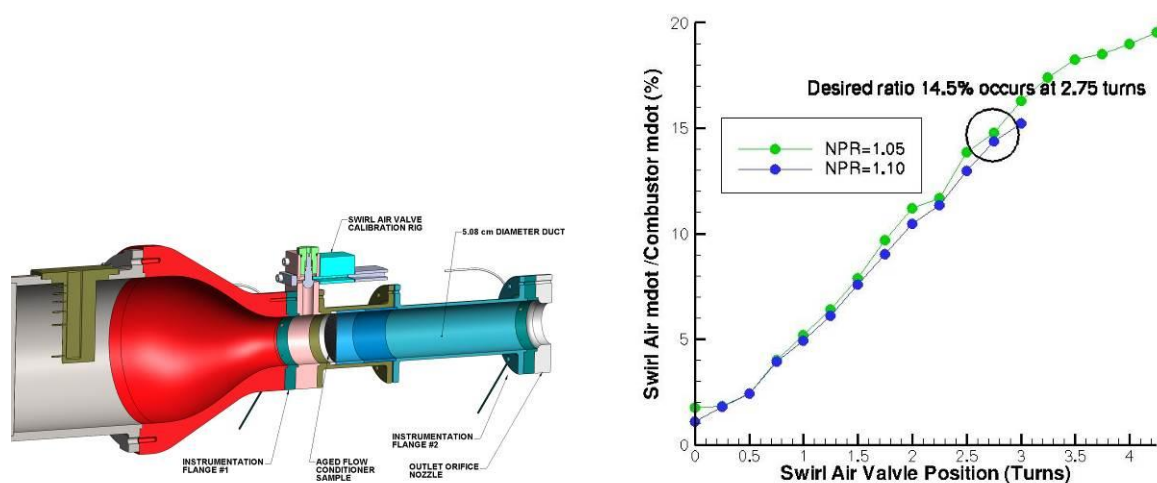

Figure 10 Swirl Air Valve Calibration Test and Data.

The CJES units are very small compared to similar acoustic test rigs in other facilities, so the probability that there would be rig noise issues is high. Some sort of noise attenuation flow conditioners had to be found. Before the flow conditioners were selected a test was planned in the NASA Small Anechoic Jet Facility (SAJF) to determine what types of flow conditioners would attenuate the noise and provide good flow quality. This testing was documented in a paper given at an Aeroacoustics Conference in Portland Oregon, June 2011^(18, 19). The study's conclusion was to use a low porosity honeycomb (15.6% open area) and a fine sintered wire mesh provided 20 dB of broadband noise attenuation with minimal self-noise.

Final Design/Build Contract

The concept was put out on contract for detail design and construction. Alliant Techsystems Inc., Missile Subsystems & Components Division, Micro Craft Operations (ATK/Micro Craft) won the job and built the hardware. NASA was to supply the combustor liner and the plug in ceramic material to complete the assembly.

A major hurdle in the construction of the CJES units was the brazed assembly of the instrumented section. Past failures in this area forced NASA to require American Society of Mechanical Engineers Boiler and Pressure Vessel Code inspection and documentation of the manufacturing and brazing process (by a subcontractor). This requirement allowed NASA review and approval of the process which is normally a trade secret. The qualification of the brazing process added 18 months to the schedule, but did supply acceptable assemblies. (I could go on here at length. This has been a NASA wide problem).

Ceramic Combustor Liner and Plug Development

The combustor liner concept had many challenging features for a casting (see Figure 11): 32 through holes, an undercut annulus, a cylinder, and a conical section. To develop a mold for this part the author worked with a team of technicians. An additive manufacturing specialist and two ceramic casting specialists collaborated in the efforts. The mold had to have removable or consumable core inserts to generate the needed final shape. Several computer models were made and discussed as options before any mold parts were made.

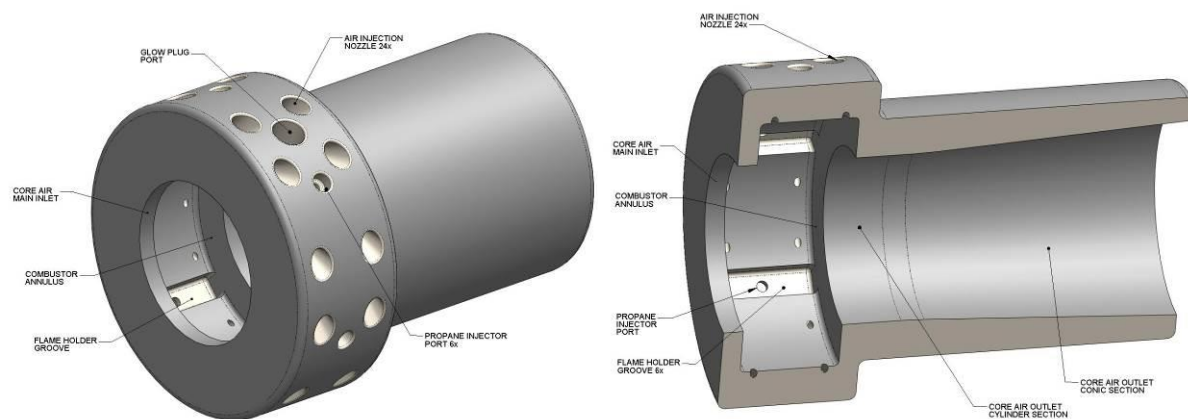

Figure 11 Views of the Combustor Liner Showing Features to be Cast

Typically a rubber core insert will form an internal feature that has to collapse for removal (see Figure 12). The combustion annulus was to be formed by a soft silicone rubber insert. To support the thin insert, twelve plastic blocks would be installed through the core main air inlet. An aluminum plug would hold the blocks in place. Over the downstream section of the plug a second rubber core would form the cylindrical and conical outlet geometry. The propane, air injection ports and glow plug igniter port are formed with aluminum inserts through the outer split mold. The outer mold halves were stereo lithography assembly (SLA) plastic parts. The hole in the left face of the outer mold is a fill port for the ceramic. The technicians suggested that we try a consumable wax insert to form the combustor annulus. These inserts could be made on an in-house wax printer.

The wax printing provided a simpler mold but the wax core shrinkage rate caused several iterations on the CAD model to obtain the desired core. The conversion software that translated from CAD file to the printer commands also turned the core into a thin wall shell with a honeycomb like support structure. The flame holder grooves ended up being solid and shrank more than the cylindrical section. The inner conical surface had to match the aluminum plug.

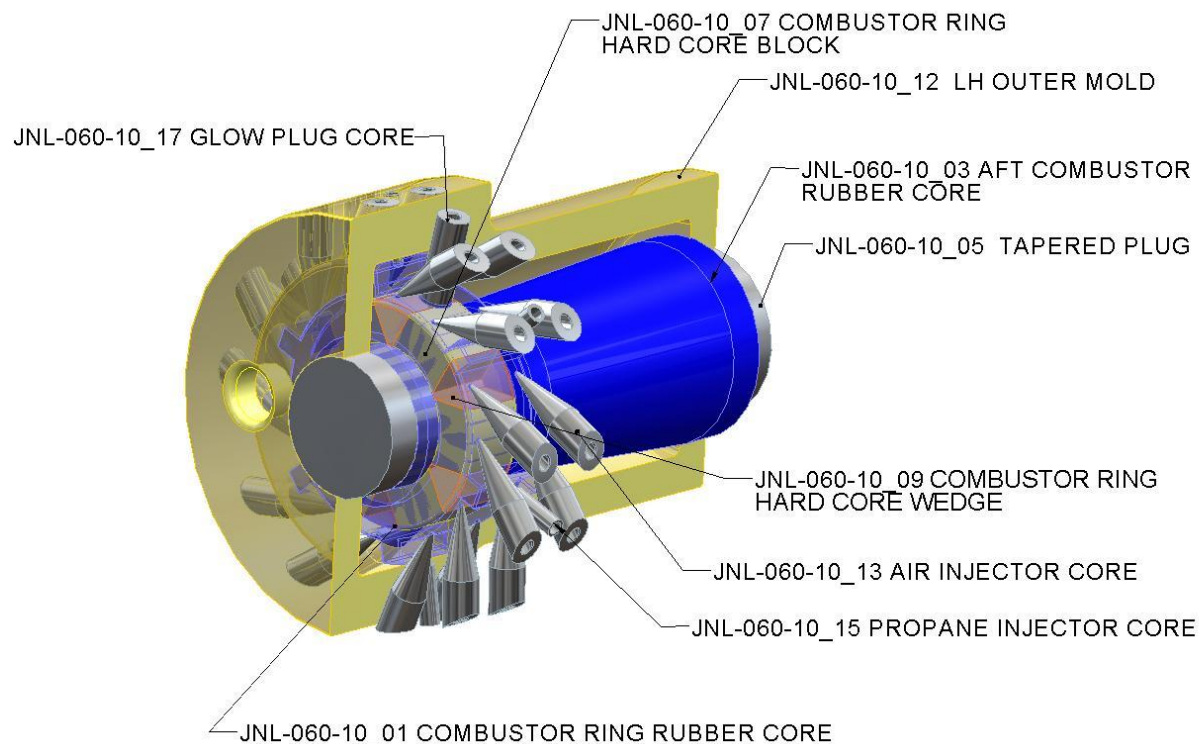

Figure 12 First Combustor Mold Version

To not have ceramic protruding (flash) into the 31 ports, the inserts had to fit into sockets in the wax core. These features could not be printed. The wax prints on a plate and builds vertically. Any round features not parallel to the vertical axis will end up being elliptical due to the liquid material fusing and shrinking. To get around this issue a SLA fixture and a set of cutters were made (see Figure 13). This gave us consistent insert seating so there was no cleanup of the cast part ports after firing the ceramic.

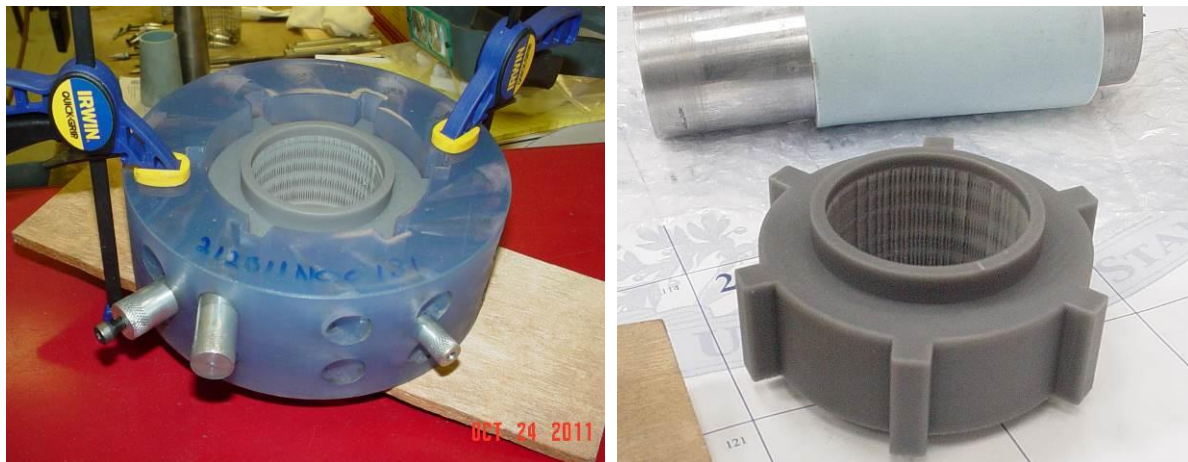

Figure 13 Wax Core Insert Cutting Fixture and a Wax Core

Once the mold was complete the next phase of development began. The selected combustor liner material was Cotronics Rescor 760, a Zirconia Oxide with a colloidal silica binder. This material had been used before on ceramic flame holders for another job and worked well. The ceramic casting technicians used their standard practice and cast the first liner.

The first casting had several problems. The material had a 10 minute pot life before it started to set. Once it started to set, it would not flow. The material would also segregate into coarse and fine grain volumes that would fracture at the transition. A frothy jelly formed at the top of the mold making the

top wall unusable. A new mold was made with the fill ports at the downstream end of the part to allow for the froth to form beyond the usable part. The material segregation issue could not be solved with a mold change so a different material was tried.

The second casting material was Aremco 646. Again a Zirconia Oxide, but with a magnesia phosphate binder. The different chemistry presented a new set of problems. This material would set after enough water had evaporated out of the mixture. While setting the material expanded first then finally shrank. The technicians found that the casting had to sit in a warm place for three days before it could successfully be removed from the mold. After one day the aluminum plug and all 31 of the port inserts could be removed to help the water escape.

Several mold release agents were tried and petroleum jelly was the best. Fine bubbles were found on all of the ports in the casting. Talks with the manufacturer revealed that the binder reacts with aluminum and certain plastics. Instead of remaking the 32 aluminum parts and the mold, the author suggested painting them so the metal did not contact the ceramic during casting. The first good ceramic casting cracked when fired at 1200°F per the manufacturer's directions. Additional phone calls to the manufacturer suggested we lower the water content of the mixture (below the printed instructions). With the above changes we were able to get a one acceptable part in three casting attempts.

Aremco would (for a contract) perform a study of ceramic grain size mix versus shrinkage and develop a NASA formulation with lower shrinkage. Two formulas were sent to us for evaluation. The coarse version proved to be too thick for the vacuum outgassing to work at the low water levels required for reduced shrinkage. The trapped air in the material caused the part to fail on curing. The fine grained version released the air and survived firing. During firing the part developed fine cracks on the surface (crazing). Reducing the water content further (nonfilling of the mold being the lower limit) the castings were improved. Figure 14 below shows the results of the improved material.

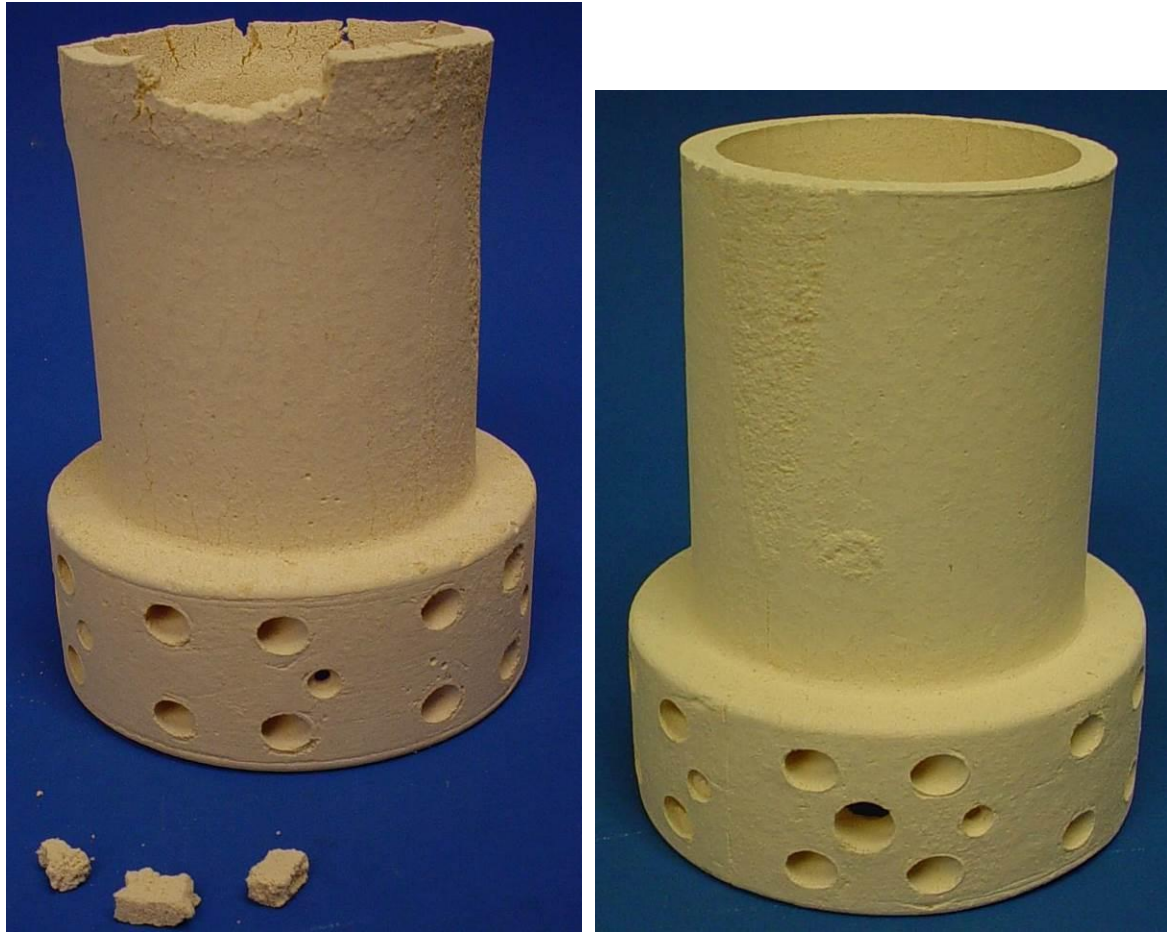

Figure 14 Failed Ceramic Combustor Liners, New Coarse Material on the left, and New Fine Material on the right

At this point the model hardware was due to be delivered in two months. A year had gone by in developing a casting technique that yielded 50% good parts. The Author decided to work an alternate solution to produce a combustor liner and plug in parallel with the ceramic effort. Direct metal laser sintering of cobalt chrome material looked to be the best option we had in-house. The same team of technicians would be working this solution so they knew the problem well.

The plug assembly in cast ceramic was not as involved as the liner, but still challenging. The purpose of the plug-vane is to redirect the swirling flow out of the combustor annuls and mix it with the main core flow. Ideally one would get non swirling flow with uniform temperature and velocity profiles. Figure 8 shows the plug-vane's location within the CJES assembly. The plug vane is retained with a 1/8 turn twist

lock. This retention method aligns the vanes with the flame holders in the combustor liner. The mold was made in six segments (symmetry split) as shown in Figure 15.

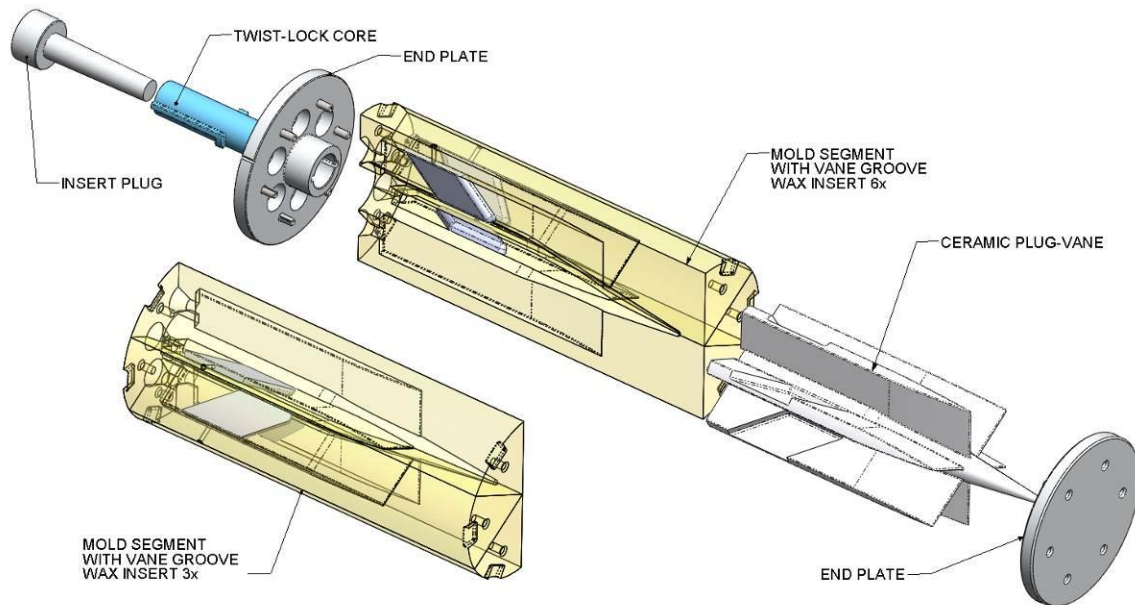

Figure 15 Ceramic Plug-Vane Mold Details

The end plate with the twist lock core included the filler holes. The wax vane groove inserts were retained with pins. The wax inserts were also made on the wax printer after it proved to be much faster than hand working them from wax sheet stock. This casting had similar issues with the ceramic materials. This mold was tighter than the liner mold, and took five days to out gas enough water for the Aremco material to set up. The Cotronics material was tried only once and the part quality was so bad we never attempted any changes to make the material work.

We went through three mold variations for the plug-vane casting. The plug diameter was increased, the radii on the twist lock were enlarged, the groove insert radii were also enlarged and the segment locking arrangement/end plates were changed. With the improved Aremco material, we obtained good surface finish, but the parts developed fine cracks over the twist-lock grooves and were unacceptable. At this

point, the decision was made to scrap the ceramic versions and concentrate on the metallic component development. A slide presentation covering this development (part of a letter of accommodation for the technicians' efforts) is included in an appendix.

Direct Metal Laser Sintered Fabrication

The Direct Metal Laser Sintered (DMLS) fabrication machine we used was from 3D Systems a Sinterstation® Pro DM250. This machine was serial number 002, almost a prototype. Earlier work the author had done on this machine, flow conditioners, had required two firmware updates to be written, one update to the Realizer translation software, doubling the machine memory and adding the cobalt chrome material to our stock supply. All of the computer related changes were due to the extreme feature rich nature of the flow conditioners. Some of the flow conditioners were in excess of 4GB in file size before translation to the machine's sliced file format. The DOS 6.2 based machine required some workarounds to deal with the geometry.

The detail design/build contract with ATK-Microcraft would supply one set of flow conditioners with each CJES unit provided. We needed to have at least one set of spares flow conditioners on hand for the test. Past experience in the Jet Noise Laboratory had shown that 5 μ filters in the airline will not ensure that the flow conditioners will plug with dust and dirt from the old pipes. In addition the combustor could produce soot at some operating conditions. The proposed 20 μ filter media to attenuate noise could easily plug with a light layer of soot. Having spare flow conditioners is necessary for a test in a facility that costs \$20,000 an hour to run.

The fan flow conditioner was roughly 6.50" on the outer diameter by 3.85" on the inner diameter by 1.50" long. It had a 0.50" thick honeycomb with 15.6% open area followed by thin walls to support the sintered screen. The honeycomb holes were .025 across the flats of the hexagons. This part had to be built using the DMLS because the 2500 holes would have to be burned one at a time on an Electrical Discharge Machining (EDM) machine. That process would require custom tooling and several months to do. The cost for that feature alone was prohibitive. The hexagonal holes were picked over round holes because the translation file from SolidWorks to the DMLS format converts the solid surfaces into triangles. A hexagonal hole can be defined with 12 triangles, but a round hole depends on the resolution needed to define the hole. The part file, on the coarsest setting was two orders of magnitude larger with round hole versus hexagonal holes at the same resolution. Since we were running into software/hardware limits with the number of features, hexagonal holes had to be used.

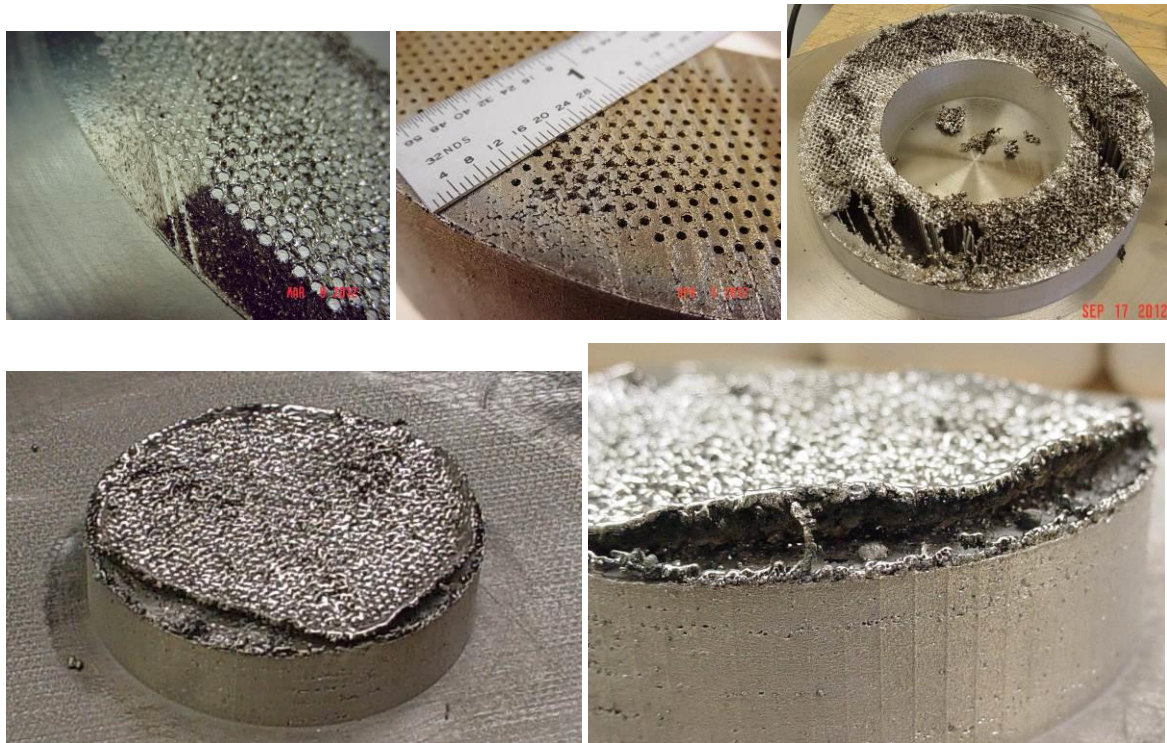

Figure 16 DMLS Failed Fan Flow Conditioners and Core Flow Conditioner

The first attempts at building the part failed as shown above in Figure 16. The part had many material defects from lack of fusion between the layers. With second part, the top surface would not always fuse with the layer below and the material would curl up and jam the machine from depositing the next layer of metal powder. The 3D Systems field technician could not diagnose the problem and we had to get a member of the original design team from Germany to figure out the problem. The issues turned out to require a replacement laser, complete realignment of the optics, new seals on the laser cavity, additional purge of the laser cavity (metal powder got on the lenses) and changing the powder drop wiper blades to the latest revision. We also found that there was a sweet spot on the build platen where the parts would build. Eventually we produced one good fan flow conditioner blank with our machine. The second part was built in Germany on their developmental machine. That effort generated further software/hardware updates. The core flow conditioners were not a problem after the fan flow conditioners. There were minor tuning issues with the shift from stainless steel to cobalt chrome.

The next fabrication challenge was to attach the fine sintered screen to the solid flow conditioners. The sintered screen material was 0.018" thick 316L stainless steel wire meshes. Conventional Tungsten Inert

Gas (TIG) welding burned through the thin screen leaving gaping holes or unfused sections. Brazing was not an option because the braze alloy would wick into the screen and fill it. We settled on electron beam welding the screen to the flow conditioners. Unfortunately our shop had exceeded the old electron beam welder they had so we needed to outsource the welding. We were fortunate in finding that the local Department of Energy, Thomas Jefferson National Accelerator Facility (JLab) had electron beam welding capability for welding their superconducting alloy parts for the Continuous Electron Beam Accelerator facility.

The author obtained permission to use their equipment and operator, then worked with the E-Beam welding technician to develop the process for welding the screen to the flow conditioners. The screen locating step size was adjusted. We found we had to add a filler wire to the joint to obtain a complete joint. The JLab machine did not have automated wire feed. The NASA LaRC shop water jet cut the screen material, to a tight fit then cleaned it for oxygen service. The Jet Noise Lab Technicians spot welded the screen in place and then spot welded on the TIG wire filler. After four sample trials, we were able to weld the sintered screen to the flow conditioners. <https://www.jlab.org/home>

The next parts for DMLS were the combustor liner and the plug-vane. The combustor liner design required a separate build file, from the CAD file, so all of the finished part details could be manufactured. Like the wax printer holes not aligned with the build axis had to be left out and Computer Numeric Control (CNC) machined after DMLS building. The combustor annulus and flame holder grooves were built in the part. An indexing tab had to be included for CNC lathe set-up so the operator could match the alignment of all the holes to the flame holder grooves (see the left hand view in Figure 17 below the tool). In the DMLS build process, the combustor annulus and flame holder grooves were filled with “supports” a web like structure that secures the outlet duct (remains of the supports are shown in the right hand view of Figure 17).

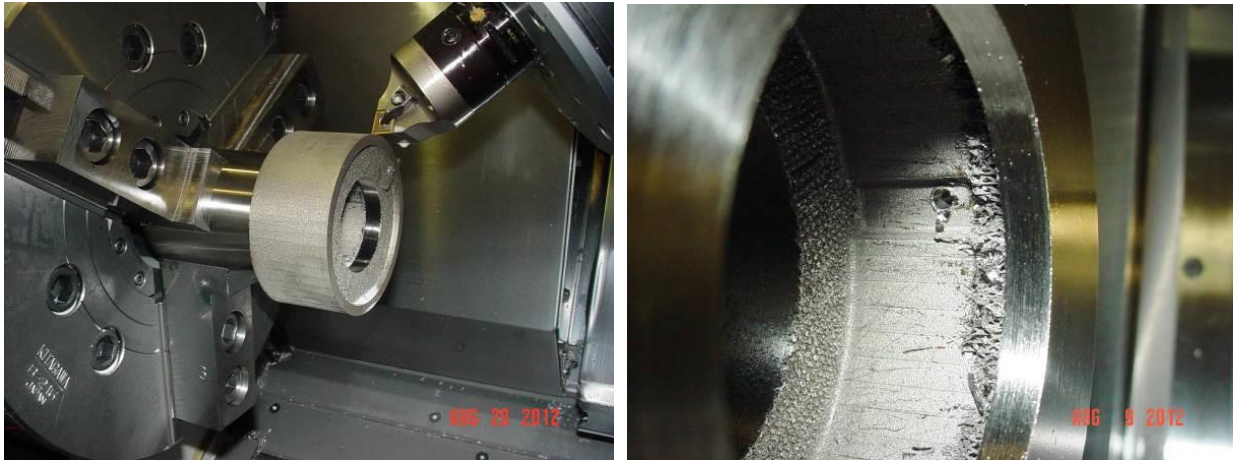

Figure 17 DMLS Combustor Liner on the CNC Lathe

The propane injector and glow plug ports were bored with conventional tooling. The air injection nozzles required special tooling. A flat bottom end mill produced the starter location. A solid carbide drill bit made the starter hole. A custom set of single flute straight tapered cutters, in solid carbide, finished the air injection nozzles. To save on cost the outer diameter of the combustor liner and the combustion annulus were left in the “as built” condition.

All of the DMLS parts were given a solution annealing cycle in a furnace. A prior test in the Jet Noise Lab of a DMLS cobalt chrome part revealed that the “as-built” part was not fully sintered. When tapped the nozzle did not ring (thunk). After running the nozzle at 1600°F for 8 hours, it would ring when tapped. To insure that DMLS parts have consistent properties the parts are solution annealed. In addition there are pull samples made with each batch and tested in a lab for material property documentation. These requirements have been added to the Langley Model Systems Criteria for wind tunnel model testing. A finished combustor liner is shown in Figure 18.



Figure 18 A Finished CoCr Combustor Liner

The plug-vane development was not as involved as the combustor liner but did have its' own unique challenges. The twist-lock feature was made as a sample part so we could evaluate the fit on the mating part. Since the inner diameter of the twist-lock is 0.6", it is too small to machine the interior features to clean up. The "as-built" finish and tolerances have to fit the mating part. The part was modified to build the plug-vane from the trailing edge plug cone tip. This eliminated supports from being built inside the twist lock feature. The first trials proved that the supports from the translation software were too weak. They broke and the part tilted during building leading to a failed part (see Figure 19). The author added .025" thick webs and .050" ribs between the build plate and the trailing edges of the vanes. These supports were successful. The plug tip support was also reduced from the part outer diameter to 3/8". We were able to build four plug-vanes at a time with this version.

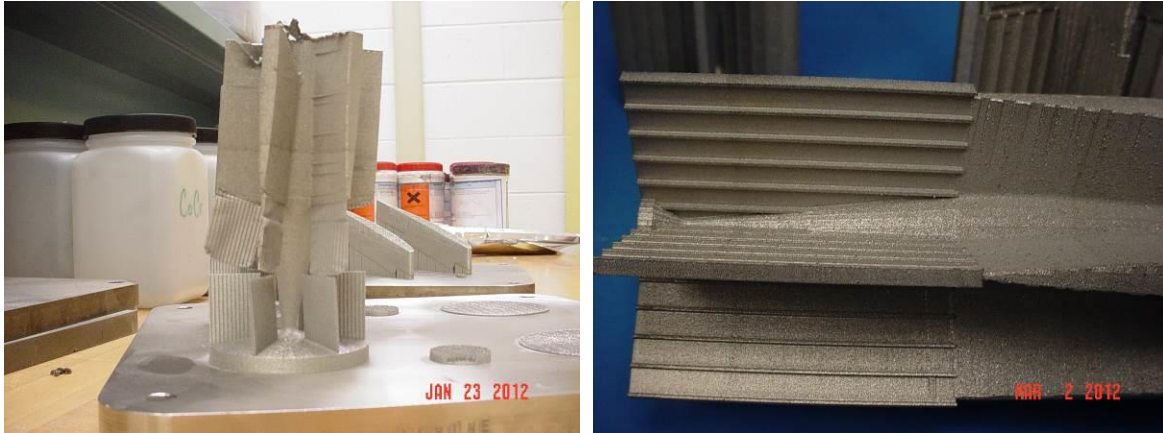

Figure 19 DMLS Plug-Vane Parts. The build on the left failed due to support failure then deflection. On the right is a batch of four units with CAD generated supports.

Initial Testing of the Compact Jet Engine Simulator

Many preparations were required before we could test the CJES in the Jet Noise Laboratory (JNL). The combined purpose of the CJES testing was to:

- 1) Develop the CJES from an untried burner concept into a useful aeroacoustic test rig.
- 2) Develop an operating procedure for the CJES
- 3) Determine the operating envelope of the CJES
- 4) Prove the safe operation of the CJES using the hardware that would operate it in the 14x22' Subsonic Wind Tunnel.
- 5) Develop the control software to an operational state.
- 6) Have the safety reviews required by LaRC to allow testing of this hardware in the 14x22' tunnel.

To do this we had to modify the liquid propane supply to provide gas to the CJES valve pallet. Modify the air supplies to the large Jet Engine Simulator to supply the CJES. Wire in the CJES control PLC to the facility. Integrate the CJES controls with the JNL controls and safety interlocks. Write an operating procedure. Once this was done, operate the CJES with air and nitrogen to simulate operation and demonstrate all of the facility safety interlocks. Produce a documentation package of the above efforts and present it to a safety review panel for release to begin testing.

The initial configuration we would run would be the burner section with no flow conditioner. We would use a ceramic liner because the metal part was not built yet. A set of thermocouples and a total pressure probe would replace the instrumentation section for the first runs so we would not damage a half million dollar assembly during burner checkout. The arrangement is shown in Figure 20. The large blue cylinder houses the propane control valve assembly. It is enclosed in a purged container because the 14x22' tunnel is not rated for fuel use. It was most cost effective to place the hardware in a vented container than to upgrade the 1970's vintage wind tunnel. The propane vaporizer is visible, a green cylinder, between the Jet Engine Simulator (acoustic foam covered burner rig on the left) and the CJES stand fairing.

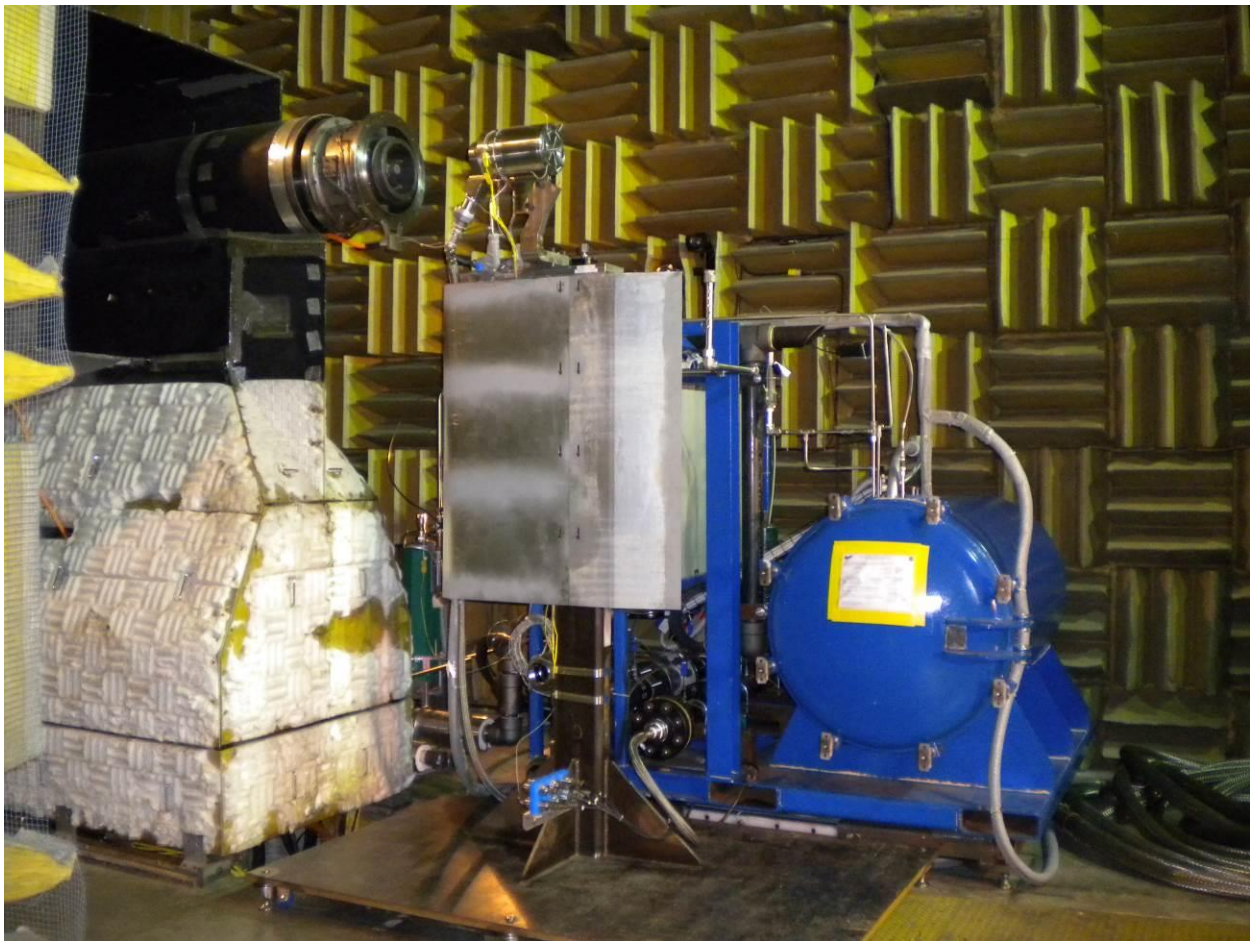

Figure 20 Initial testing Configuration of CJES Combustor in the Jet Noise Laboratory

There were numerous fixes required to the system before we could achieve a continuous burn. A safety required check valve had to be removed from the vaporizer liquid feed line to get continuous fuel flow. The vaporizer needed to equilibrate the liquid level with gas feedback that the check valve prevented. The control software was changed often. We were able to light the burner, but the flame would not stay in the combustor annulus. See Figure 21 a).

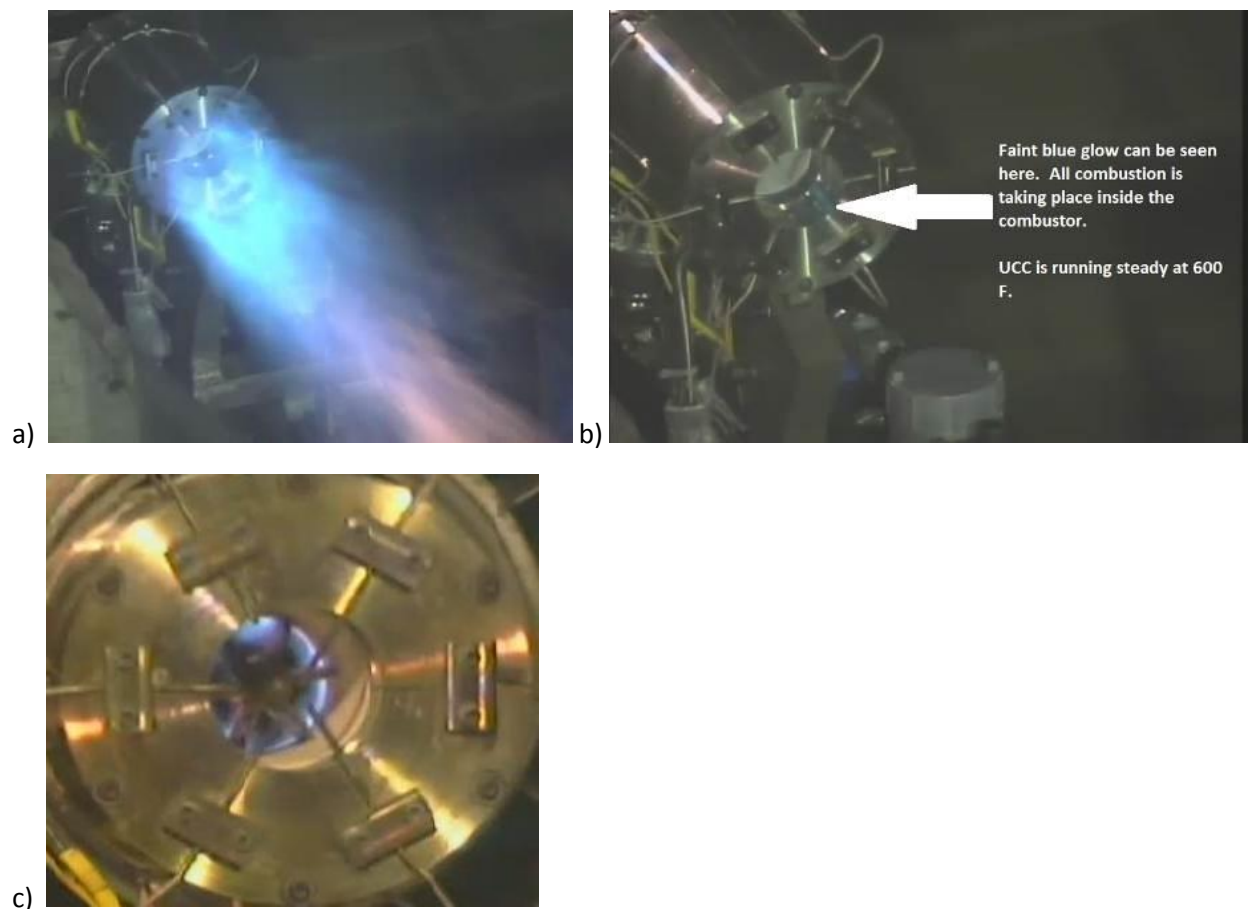

Figure 21 CJES First Light (a) and Combustion in the Annulus (b) a Faint Blue Glow, Combustion in the Annulus from Aft Camera (c).

We had to add another camera to look up the exhaust of the CJES to see the combustion when it was burning correctly. The initial combustion attempts could only cover a very small portion of the desired

operating envelope. We needed more instrumentation to find out what was going on. Ramping up the fuel and air to achieve higher mass flows ended in blowing the flame out of the annulus or a flame out. The author designed a total pressure rake that could replace the glow plug in the CJES unit (see Figure 22). This would allow us to run air through the CJES unit and measure the swirl rate in the annulus. The unstable combustion in the annulus could be due to not enough centripetal loading in the annulus resulting in incomplete combustion.

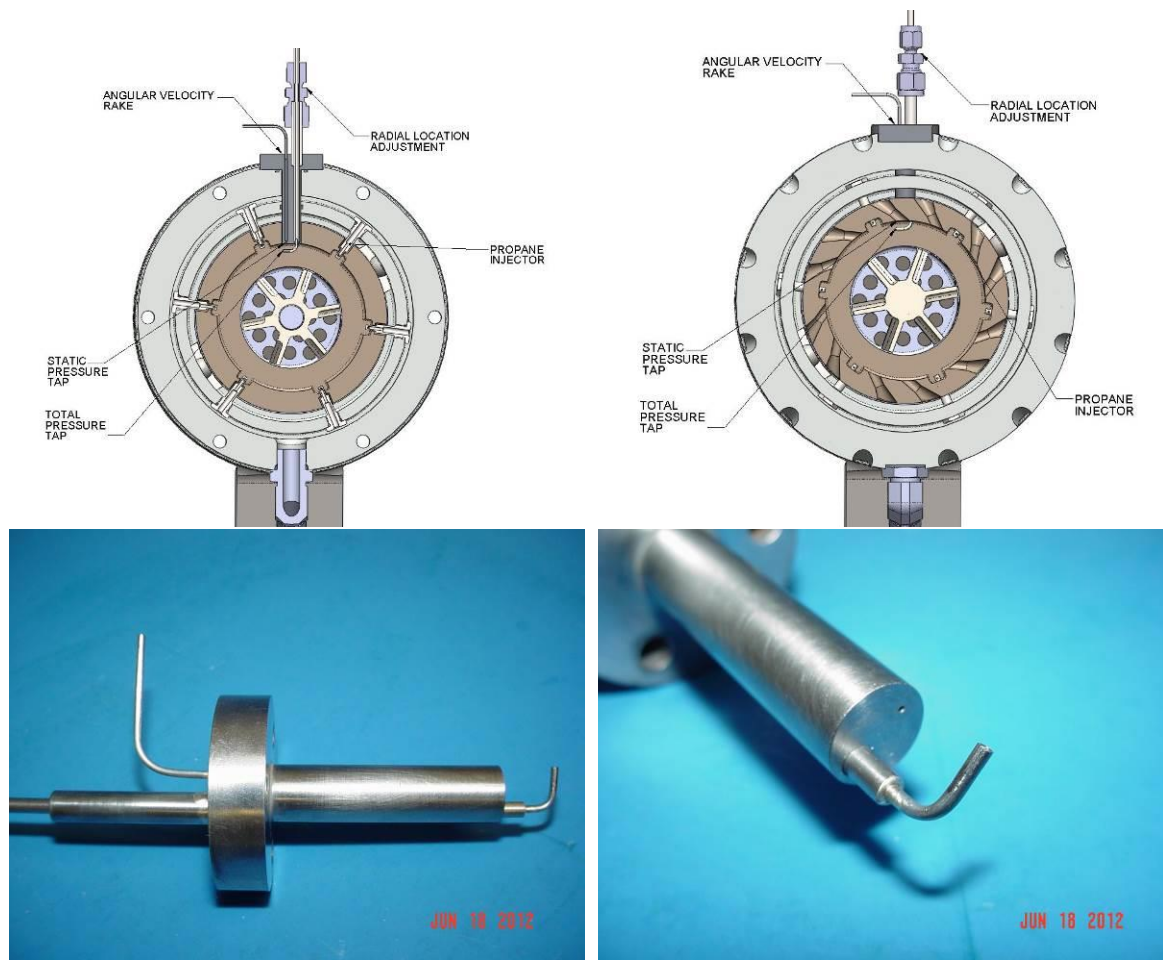

Figure 22 Angular Velocity Probe Installed in Glow Plug Port (upper left), Modified Combustor Liner with Larger Swirl Nozzles (upper right), Probe Details (lower photographs).

The combustor liners in use at the time were ceramic and cracked with several hours use. After, at most, eight hours of use the liner had to be changed. The DMLS machine had not been refurbished yet

so no metallic parts were available. The angular velocity probe provided data that as the liner cracked, the swirl air leaked through the cracks instead of swirling in the annulus. Lewis¹¹ shows in his paper that the peak flame speed, for propane, occurs around Froude number of $Fr=3500$ then drops with higher values. AFRL indicated in several papers that the Froude number range of 2000-3000 was ideal for their UCC. The tangential velocity measurements are shown in Figures 23 and 24 below. The tangential velocity dropped by 50% or more with a cracked liner. The resulting Froude numbers dropped to the point that combustion would not complete in the annulus. We noted that the swirl air velocity could be lowered to bring the Froude number into the preferred range. This would be done by enlarging the swirl air nozzle outlet diameter to .243 inches in diameter. This would provide more swirl air so we could reach higher temperatures by adding more fuel. The upper right side image in Figure 22 shows the modified swirl air nozzles. With the modification we were able to reach the takeoff conditions for the Hybrid Wing Body Test.

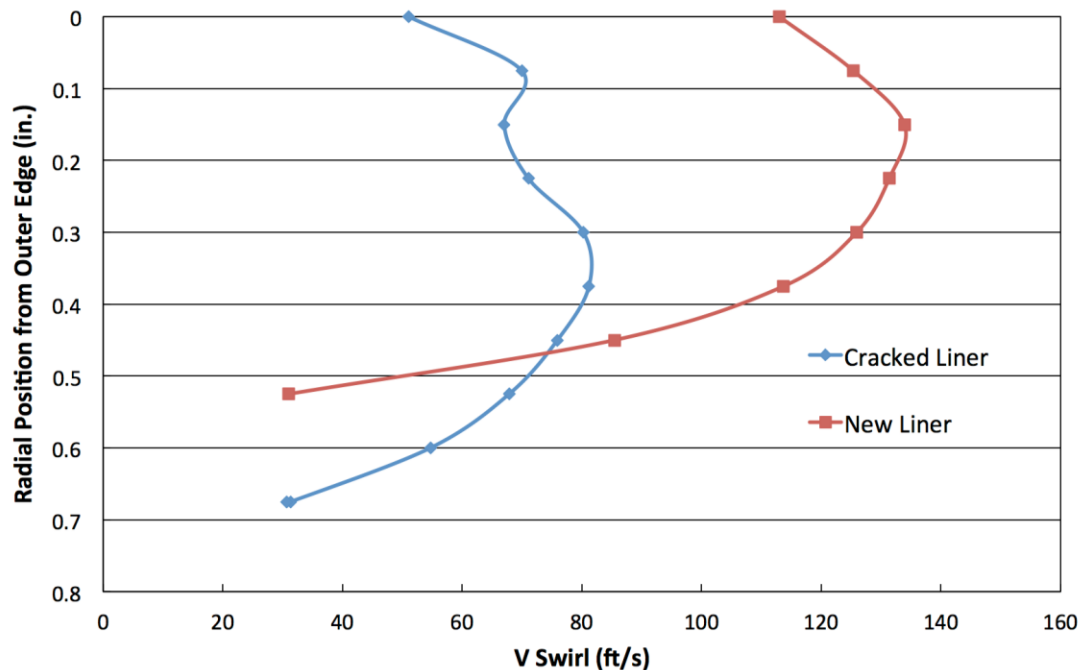

Figure 23 Swirl Air Velocity in the Combustor Annulus⁽²⁴⁾

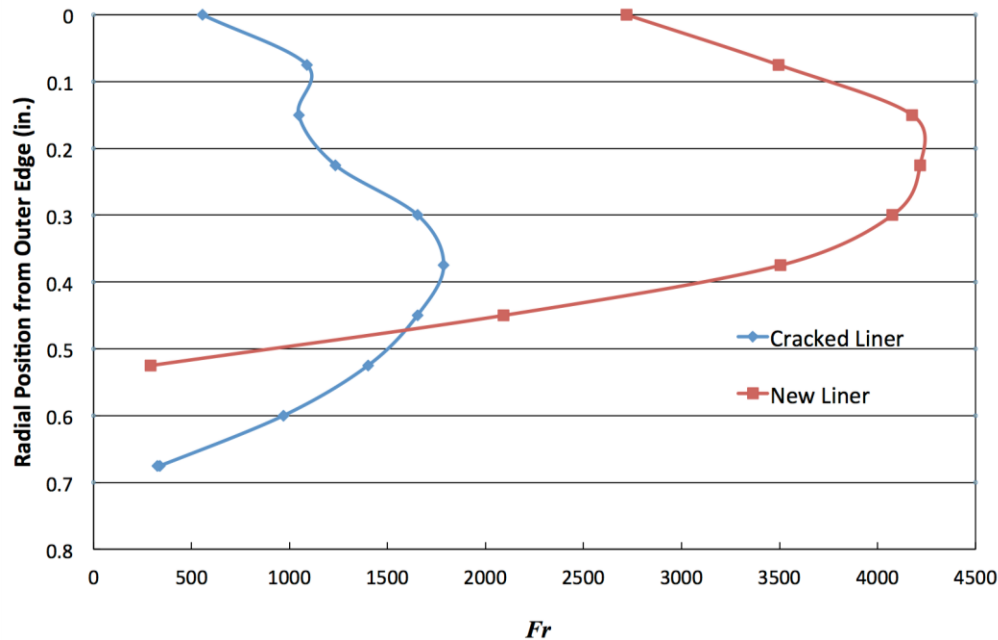

Figure 24 Froude Number for Cracked and New Combustor Liners⁽²⁴⁾.

Where $Fr = V_{tan}^2 / g_c r$

Fr- Froude number, V_{tan} – swirl velocity, g_c – gravitational constant, r - local cavity radius

While correcting the swirl air loading issue, we found that the propane injectors supplied a very high jet velocity for the gaseous propane which enhanced combustion in the plug-vane area. Part of this problem was due to using gaseous propane. The vapor pressure for propane at the tank temperature of 110F (propane tank in the sun August 2012) was 220 psi. The burner was operating at a static pressure of 15 to 20 psi. A differential pressure of 50-60 psi would have been better to mix the fuel with the air for combustion. We changed the orifice size to the maximum for the part for little to no improvement. We added a layer of sintered screen over the inlet of the injectors (figure 25 a). This was to insure that the propane manifold pressure was uniform for all of the injectors and to drop the injection pressure. This provided no benefit to the operations. Next we tried a nichrome strap over the tip of the injector to divert the flow to the sides aligned with the flame holder groove (Figure 25 b).

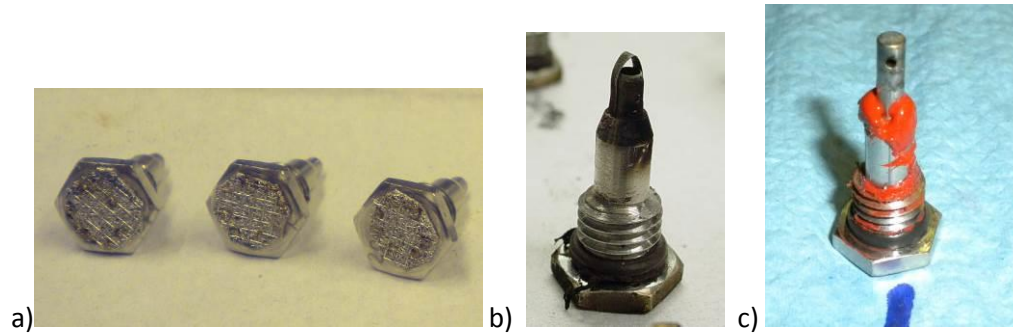

Figure 25 Propane Injector Modifications; Pressure Dropping Screen (a), Diverter Loop (b), Cross Drilled (c).

This improved the temperature profile and burner stability. The burner ran consistently but not as stable as desired. The final version was to extend the tip and have a cross drilled exit hole (figure 25 c). This version provided the most stable operation across the mass flow and temperature range. The increase in the swirl air nozzle size reduced the combustion shifting in the plug as shown in Figure 26.

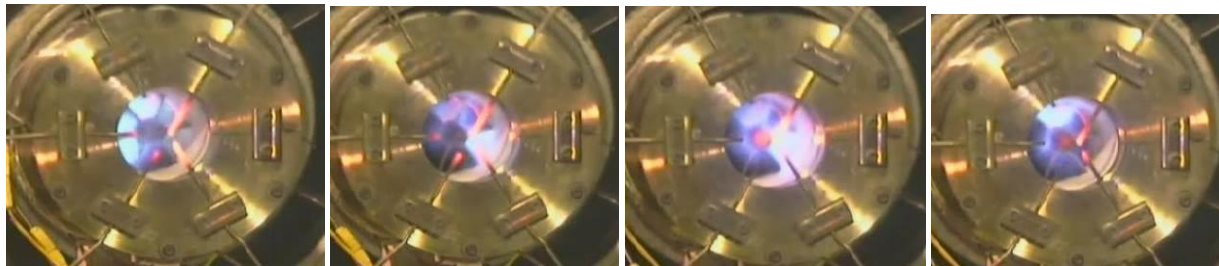

Figure 26 Combustion Switching Outside of the Annulus

At this point we had verified the control software, demonstrated how we could operate the burner at test set points and change between the set points with the burner exhausting to atmosphere. Next we had to backpressure the combustor by adding the flow conditioners and then the test article nozzle. Increasing the back pressure will change the operating characteristics of the burner.

The first runs were made with the 15.6% open area flow conditioner honeycomb. The unit started and we were able to reach the lower test set points of approach and cut back, but not take off. We assumed that the ceramic liner had cracked and we had lost burner efficiency. Upon disassembly and inspection, see Figure 27, of the unit we found that the liner had cracked and that the increased backpressure had heated the propane manifold enough to coke the propane. We found carbon deposits in the propane

manifold area where there was no air for combustion. The propane injectors were covered in carbon, on the propane side. Soot marks were evident on the inside of the combustor liner.



Figure 27 Soot Buildup in the CJES Unit After First Flow Conditioner Run.

The flow conditioner had collected carbon and fragments of the combustor liner. The unit was cleaned and reassembled with a new liner. On the second run attempt with a full flow conditioner set (honeycomb and screen) the sintered screen failed. Figure 28 has frames from the video showing the screen failure.

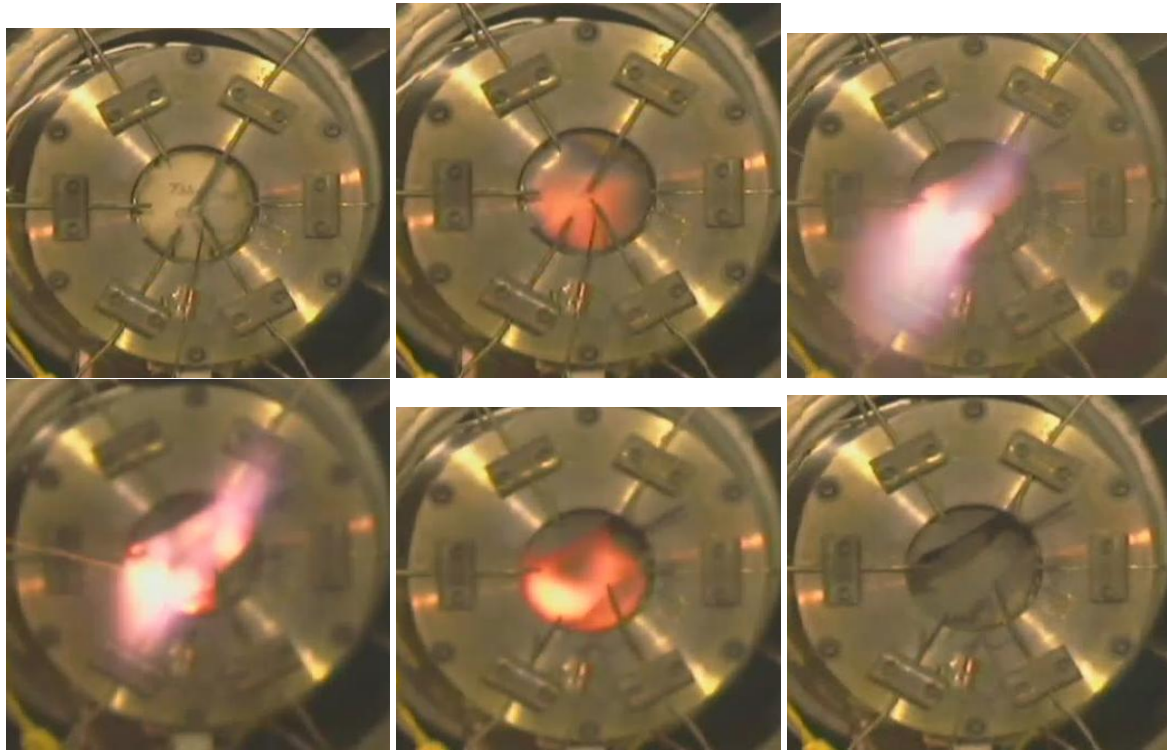

Figure 28 Failure of the Sintered Screen Flow Conditioner.

When we examined the screen it had signs of high heat and the video images suggested that soot deposits had built up on the screen and then ignited causing an over pressure to blow out the screen. The combustor liner had large deposits of carbon that had formed over the flame holder grooves. In addition there was a large amount of ceramic erosion of the annulus as shown in Figure 29.

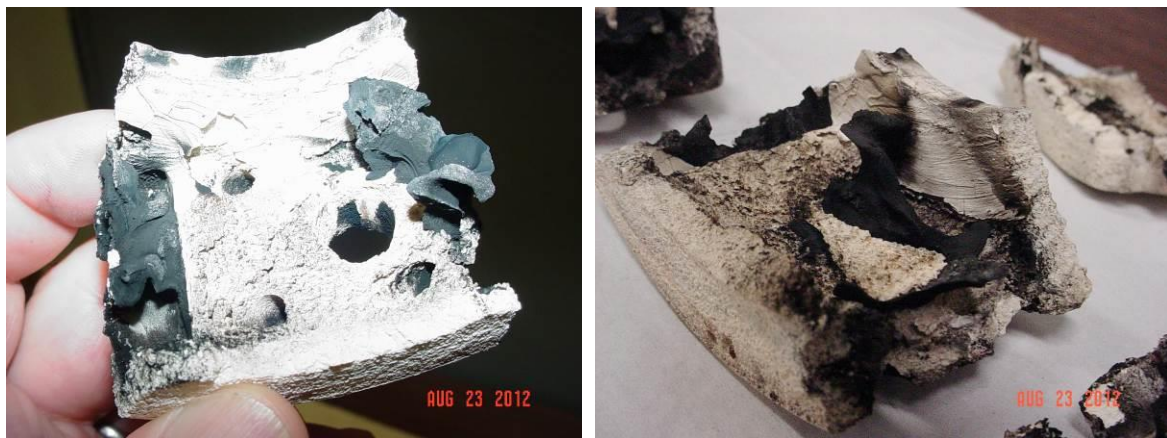

Figure 29 Combustor Liner after first Flow Conditioner Failure showing Soot Structures

The second flow conditioner failed as well. It failed from the ceramic liner cracking and shedding ceramic particles which plugged the screen until it failed from pressure over stress, see Figure 30. At this point we were out of spare sintered screen flow conditioners, so we decided to try other flow conditioner options and begin using the cobalt chrome DMLS combustor liner. The metallic liner would at least eliminate the ceramic dust problem with the core flow conditioner.



Figure 30 Second Screen Flow Conditioner Failure

We assembled the combustor to the fan plenum and the instrumentation section to measure the flow profiles of the fan and core streams and check the acoustics of the rig. Since we did not have an in-house ability to electron beam weld the sintered screens, we tried Tungsten Inert Gas (TIG) welding the screen material to stainless steel support rings. This provided the lab samples to test with cold flow and the welders' practice parts to develop their technique. There were 8 fan support frames water jet cut along with different sintered screens. While testing the flow conditioners, we found that the old air lines and electric heaters were shedding rust flakes and old dirt accumulations. These deposits collected on the 25μ filter media (sintered screen) causing pressure spikes. Once a low noise flow conditioner was contaminated, it took 3 days to cycle it through a cleaning process for reuse. The higher porosity alternate screens did not supply enough pressure drop for uniform flow into the test nozzle. The close coupling of the fan air inlet to the bottom of the fan flow conditioner produced flow asymmetry from bottom to top of the nozzle. The first alternate fan flow conditioner failed due to a lack of fusion in the

TIG weld. The welder washed melted stainless over the screen but did not fuse it to the screen. He was too careful not to burn through the screen (.025" thick). The fan plenum diverter reduced the flow asymmetry but did not eliminate it like the low noise flow conditioner. See Figure 31 for a cross section of the CJES unit showing the alternate flow conditioner arrangements.

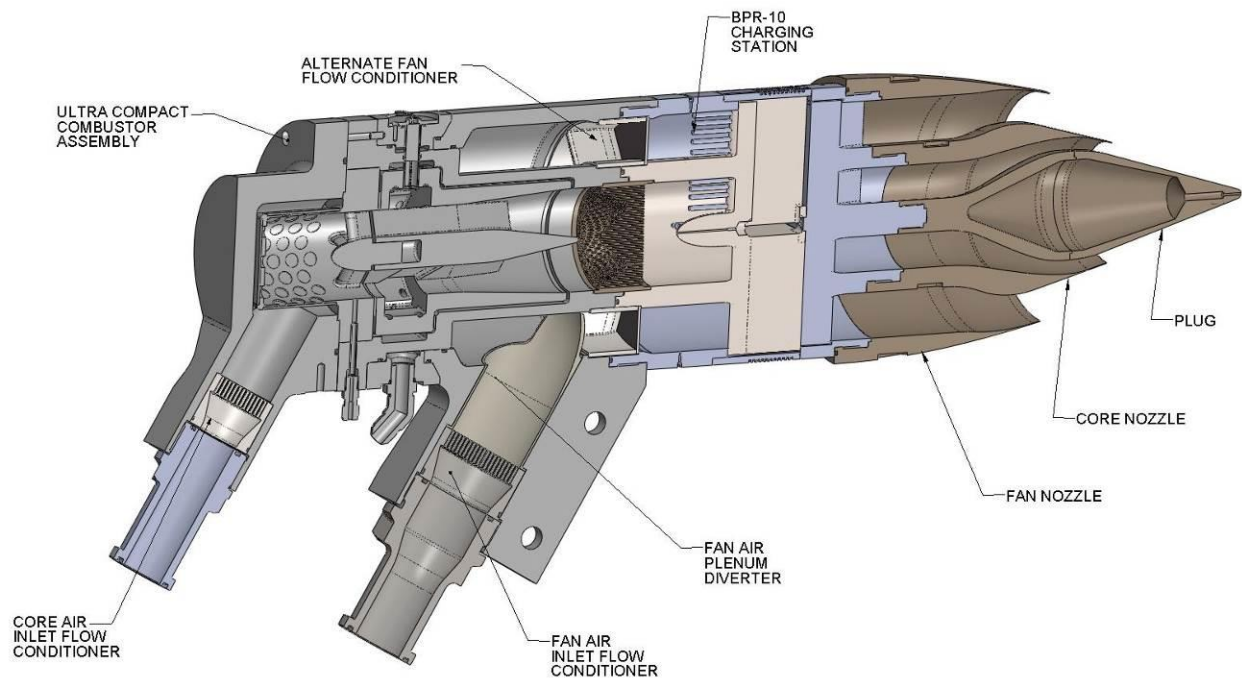

Figure 31 Section View of CJES with Alternate Fan Flow Conditioner and Fan Plenum Diverter.

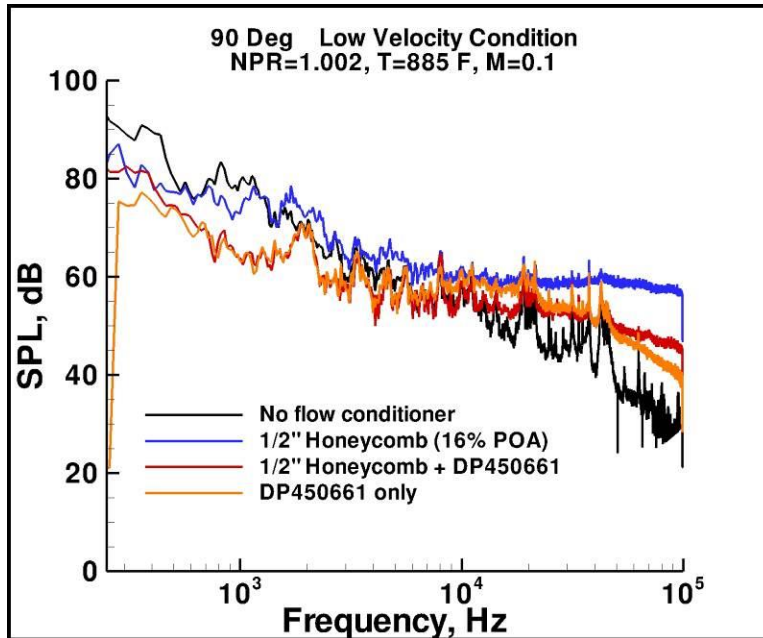

Figure 32 Comparison of Flow Conditioners in CJES Fan Stream

Based on the acoustic results shown in Figure 32, we proceeded testing the CJES with just the fine screen in the fan flow. This would improve our testing ability by not having to shut down for cleaning dirty flow conditioners. The single screen flow conditioner could be cleaned in the JNL shop ultrasonic cleaner overnight.

Combustion Instability Issue

At this time, early September 2012, we received the metallic combustor liner and resumed testing with only a honeycomb flow conditioner in the core and just a sintered screen in the fan stream. The CJES unit could reach all of our test set points. The acoustic spectra showed a burner tone that we had not seen before shown below in Figure 33.

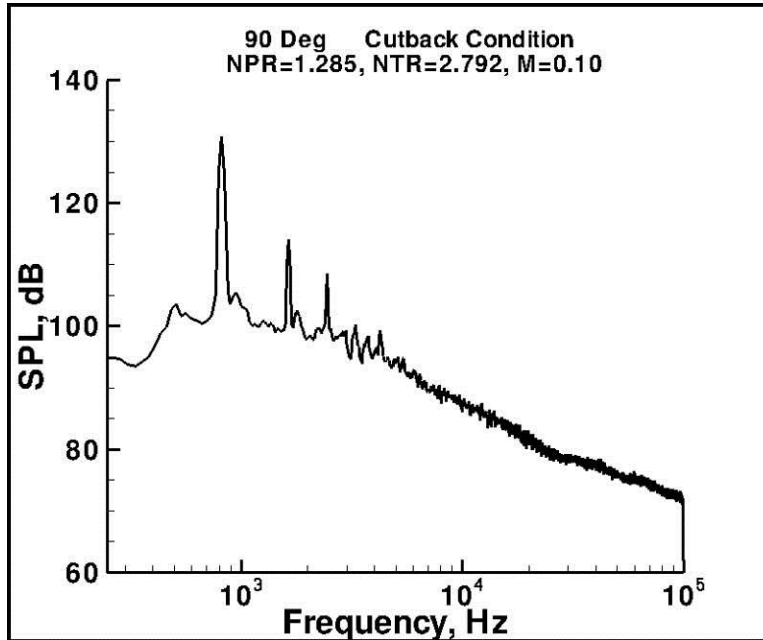

Figure 33 Combustion Driven Tones in the Core ~ 25dB Above Broadband Levels²⁴.

The tone had a first peak at 820 Hz with related harmonics. The core mass flow and temperature was varied and changed the frequency slightly. “The combustion driven acoustic instability resulted from a resonant interaction between the heat release and airflow within the combustor cavity and the length of the combustor section. Much like a Sondhauss tube²⁶, it was found that the quarter wavelength of the tone frequency was closely related to the combustor length. In fact, by switching the downstream flow conditioner and spacer ring positions, and effectively changing the length of the combustor, the tone frequency was altered in a corresponding manner”²⁴. The fixed length of the CJES restricted the changes we could make to the combustor length. Many ideas were tried to break up the planar standing wave pattern. At first variations were made modifying the existing hardware. The DMLS core flow conditioners shown in Figure 34 took 30 hours to build and another half a day to wire EDM the part off of the build plate followed by 3-5 hours on the lathe for cleanup. By the third build the part file had been tuned so the outer diameter did not need lathe work, just trimming to length. We found that one could not turn or mill the honeycomb. The material would form a burr over the holes which was very difficult to remove. Finally we reduced the Wire EDM cut height requirement from .250” down to .06”

and were able to reduce the build time by four hours. Close interaction between engineering, DMLS technicians and machinists allowed us to turn out 3 versions a week with two shift operations.



Figure 34 Some of the Combustor Change Variations tried to eliminate the Combustor Instability

After over 24 variations of flow conditioners and screens were tried, the best results came from the bottom row of pictures. The concave honeycomb flow conditioner downstream of the combustor liner with the 15.1 % open area HFM 600 sintered screen installed upstream of the plug-vane eliminated the tone. Figure 35 below shows the final arrangement with the modifications in blue.

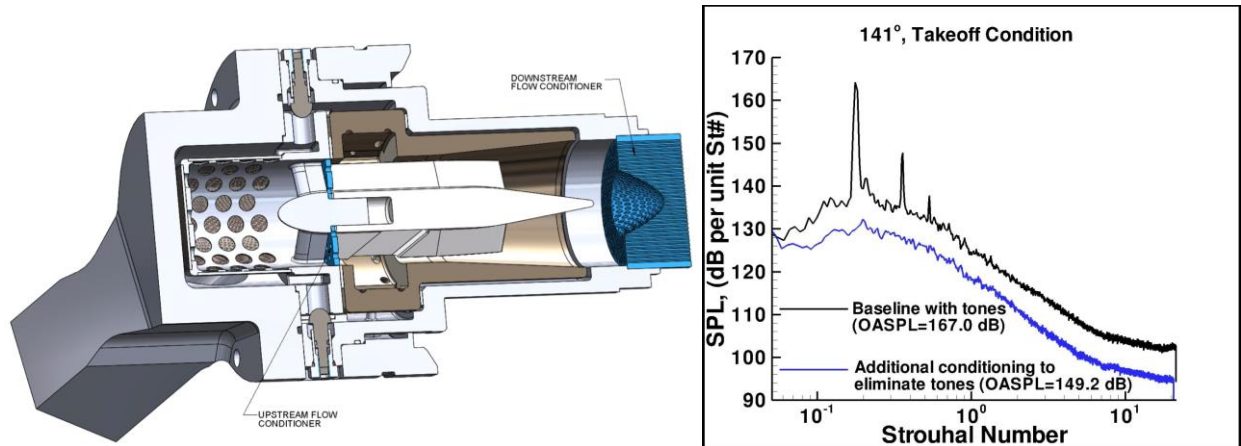

Figure 35 Schematic UCC including nonuniform downstream flow conditioner and perforated screen upstream flow conditioner used together to eliminate combustion instability tones²⁴. Elimination of Combustion Tones (left)

Once the combustion instability tones were eliminated we could isolate other noise sources in the rig. Leakage around the fan flow conditioner was one source that appeared intermittently. That source was cured by applying high temperature silicone sealant to the outer and inner diameters. The inlet pipes had short radius elbows and high velocity flows that separated. These were controlled by adding 70% open area honeycomb flow conditioners in the CJES inlets (see Figure 31) and at the pipe connection flanges. During JNL testing we had the option to use rubber hoses and a straight connection. In the 14x22' Subsonic Tunnel test the CJES units have to use the pipes because of space constraints (see Figure 36).



Figure 36 Hybrid Wing Body Model in 14x22' Tunnel with the CJES Units and Model Support

Metallic Component Part Life

The plug-vane component was a cobalt chrome DMLS part from the start of testing. The ceramic castings all cracked through the attachment feature during firing. The wall thickness changes and ceramic shrinkage were too much for the material to survive. The metal version of the plug-vane did not have an unlimited life either. Upon examining the parts after 35 hours of use the first part was retired. Thermal stress cracks had grown on 5 out of the six vanes. The oxidation patterns indicated that the upstream end remained cold (Sharpie marks remained).

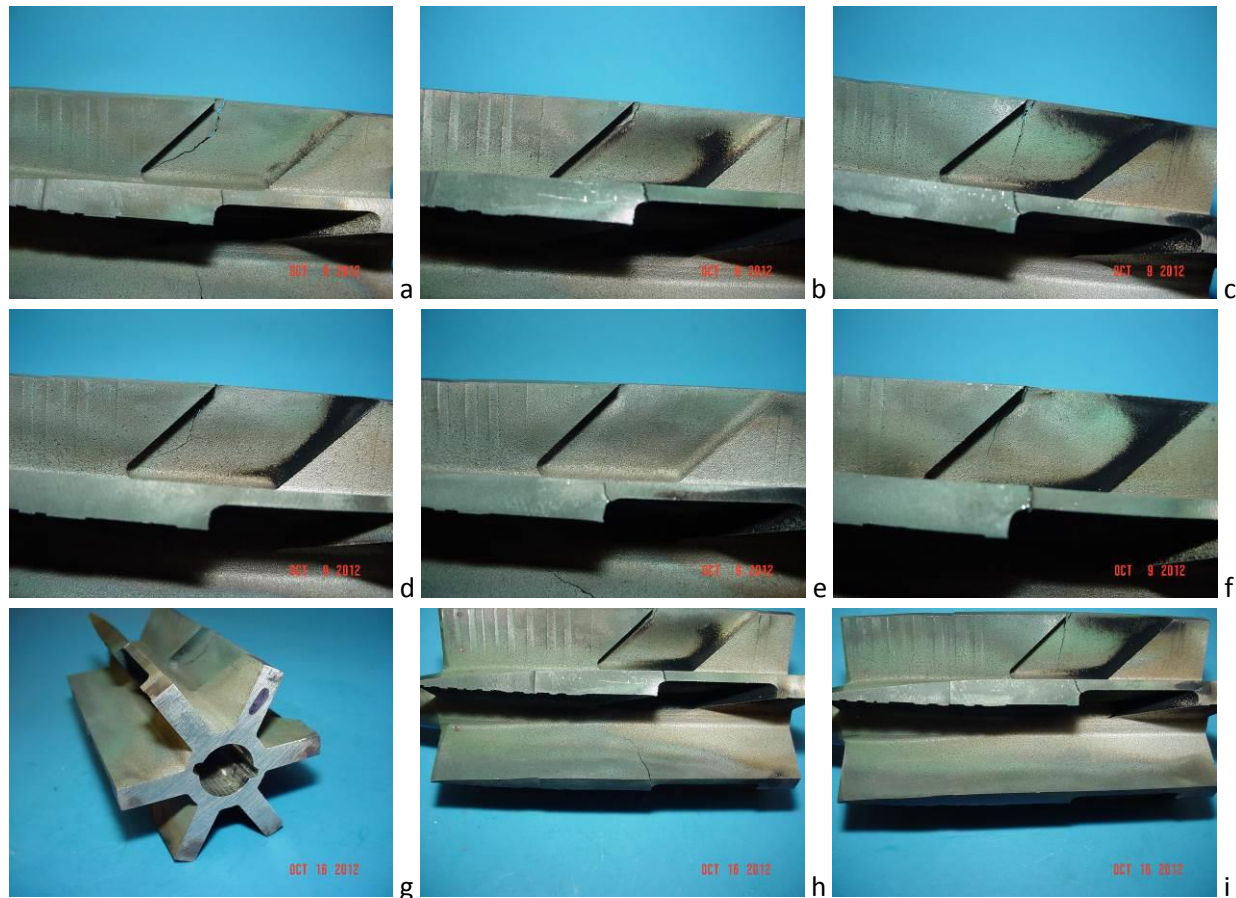
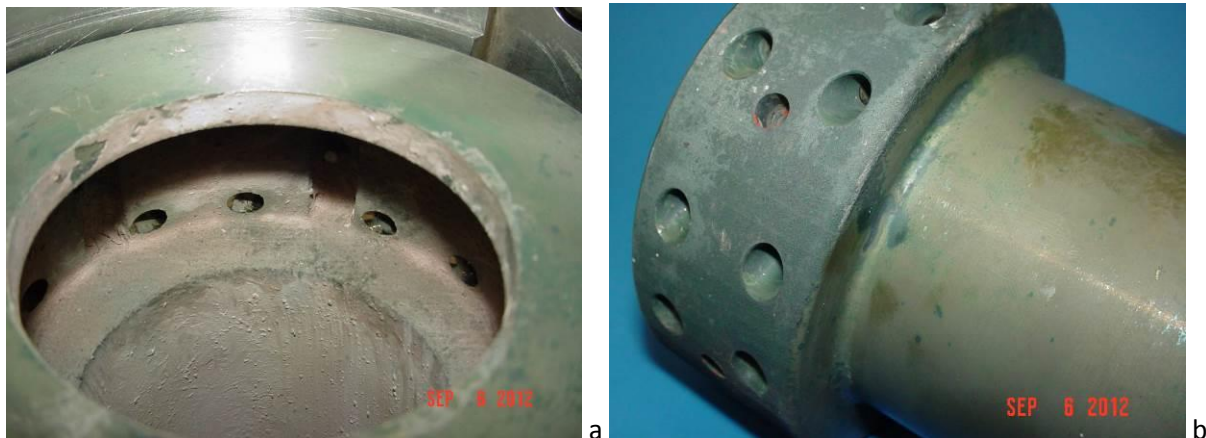

Figure 37 Thermal Stress Cracks and Oxidation of Plug-Vane after 35 hours of Operations.

Photographs a-f in Figure 37 show each of the vanes, note the differences in soot accumulation. The combustion was not uniform around the annulus, note the soot patterns in the vane grooves. Photograph g shows the upstream end with the Sharpie index mark. Photographs h and i show the oxidation patterns on the backside vanes c and e. Photograph h shows how the temperature stayed below about 600°F from the upstream right end outer surface going at an angle to the plug body at the end of the groove (silver color transitioning to green). The darker the oxide the higher the temperature. Photograph i shows that location was cooler the dark oxide not reaching the plug. The thermal stress through the thin web of the vane groove at the higher temperature caused the metal failure.

The metallic combustor liner also had a limited life due to thermal stress cracks. The first metal liner was solution annealed and then the interior surfaces were coated with ceramic coatings from International Technical Ceramics, Inc. ITC-213 is a primer ceramic that is used to reduce oxidation scaling on metal parts in a furnace environment. A second coating, ITC-100HT is an infrared reflective coating used as a thermal barrier and applied over the primer. The combustor liner is shown below in Figure 38.



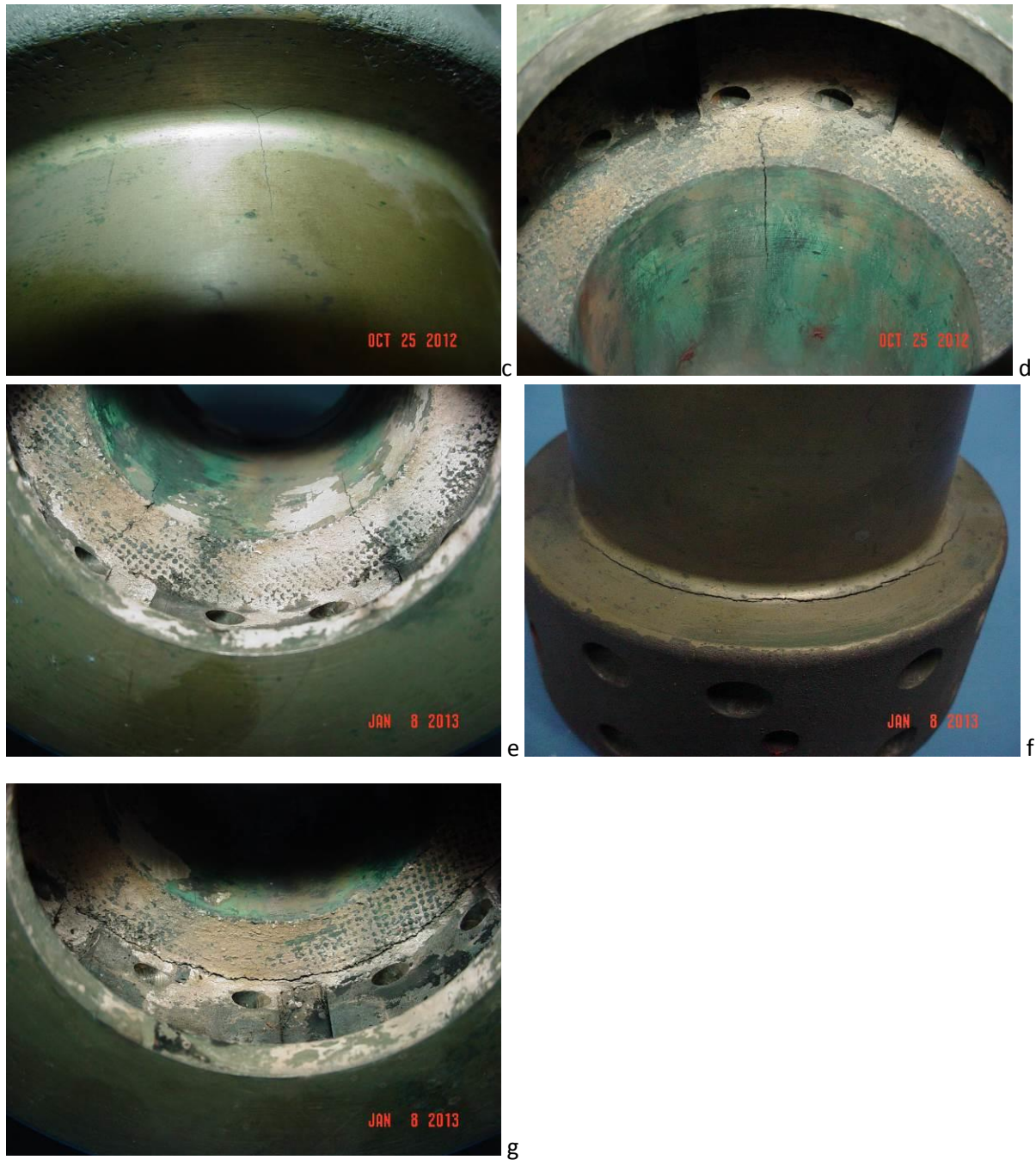

Figure 38 Cobalt Chrome Combustor Liner After initial Testing. Pictures a, b are after 6 hours testing. Pictures c, d are after 30 hours testing. Pictures e, f and g are after 50 hours of testing.

The ceramic coatings did not adhere to turned (smooth) surfaces and only partially to the as DMLS fabricated surfaces. The ceramic coating was not used again. It did not supply a noticeable benefit and

the ceramic flakes tended to plug the flow conditioner. After the first days' worth of testing the liner showed no deterioration. After a week's worth of testing (pictures c & d) cracks appeared. Pictures c & d show the inside and outside views of one Y shaped crack. This was one of two axial cracks that were present at the 30 hour inspection. At the 50 hour inspection the two axial cracks had not changed visibly (see picture e). A circumferential crack that spanned 150 degrees of arc had appeared (pictures f & g). This crack was at the junction of the annulus wall and the downstream face. This crack would likely have split the part in two if use was continued. The life span of the metallic liner was set at 40 hours. The location of the crack would not have produced a catastrophic failure if it separated the liner. There was a fillet radius and a rim that would not allow the liner to shift downstream and the flow conditioner also captured the downstream segment. The HWB test was only scheduling 32 hours of CJES operation so we were confident a major rebuild of the units would not be required during the test cycle.

Detail modeling of the combustion, temperature profiles and internal flow of the CJES were not attempted at this time. The short development cycle to the test schedule did not allow for it. In addition there was no budget to outsource this effort. The thermal analysis of the charging station by ATK-Micro Craft took a year to examine the thermal transients of a cold start to the takeoff condition. Modeling the reacting flow in a UCC has been the subject of several doctoral thesis sponsored by AFRL.

Results Summary

The CJES units were compared to Boeing's Low Speed Aeroacoustic Facility (LSAF) and are shown in Figure 39. Boeing designed the low noise nozzles to be used in the HWB test and had a set of our baseline nozzles to test. The Jet Noise Lab data could then be compared to the Boeing data. The spectra compare very well in the mid frequency range. The 2-3 dB difference in the low frequency range could be due to the treated fuel pallet that sat below the microphones and may have shielded the downstream microphones. The LSAF facility uses a vacuum pump to remove the external boundary layer over the fan nozzle which could explain the reduced low frequency upstream noise for the CJES.

The rise in high frequency noise at all angles of 5-10 dB is concerning. The behavior of the spectra is very similar to the high frequency lift observed from self-noise of the honeycomb flow conditioners¹⁹ before the fine sintered screen was used downstream. In that study the fine screen was always able to

attenuate the honeycomb self-noise. The previous study was at a much smaller scale and had a straight line flow path. The core stream does not have the fine screen to filter the honeycomb self-noise.

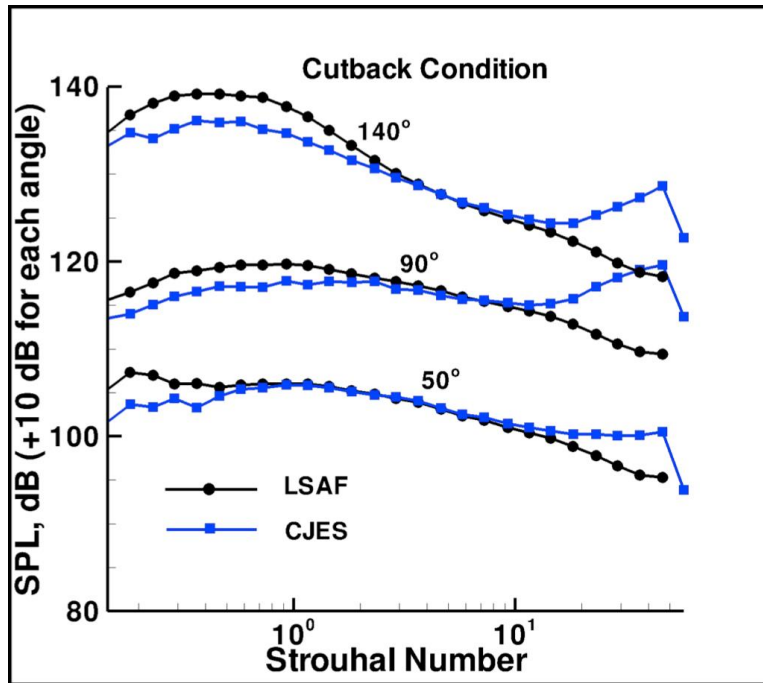

Figure 39 Far-field one-third octave acoustic spectra with CJES and LSAF operating at nominal original cutback condition: $NPR_{core}=1.285$, $NPR_{fan}=1.508$, $NTR_{core}=2.792$, $NTR_{fan}=1.135$, $Mwt = 0.10$. A 10 dB addition to 90° spectra and a 20 dB addition to 140° spectra were applied to better visualize the data, as is the case for the remaining spectral figures²⁴.

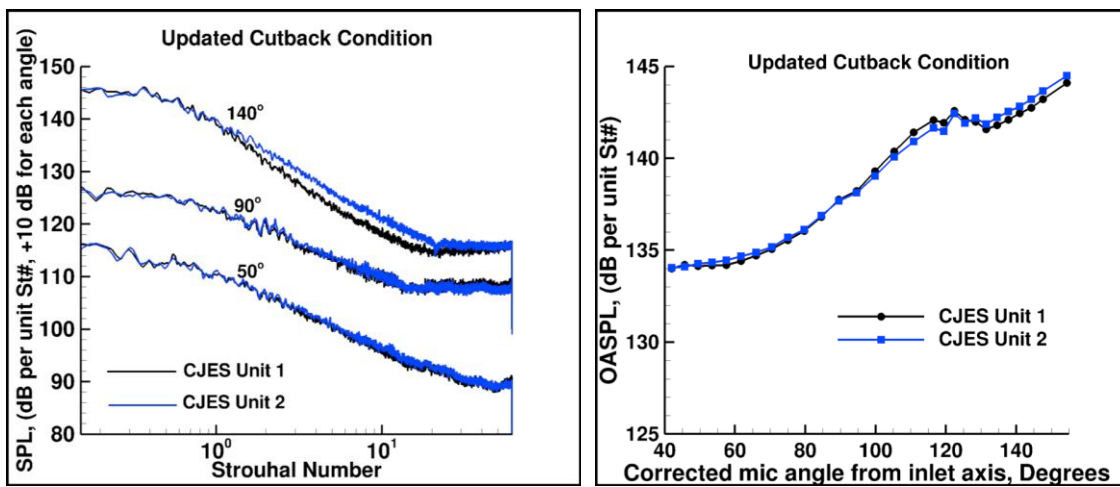

Figure 40 Far-field acoustic spectra with axisymmetric nozzles and CJES operating at updated cutback condition: $NPR_{core}=1.240$, $NPR_{fan}=1.461$, $NTR_{core}=2.721$, $NTR_{fan}=1.124$, $Mwt = 0.10$ showing a) spectral and b) directivity differences between CJES units²⁴.

Before proceeding with a the HWB test in 14x22 tunnel it is necessary to check the consistency of noise output from the two CJES units. Large differences between them would invalidate a twin engine test of jet noise shielding and interaction. Each CJES unit was tested separately with its own control system. There was one exception, the second set of final flow conditioner had not yet been built so the initial set was used for both units. Figure 40 “shows the consistency between the two separate units tested over a month apart as two different simulator build-ups, both using axisymmetric nozzles. The spectral comparisons are quite close with the exception of a mid-frequency difference between units at aft angles that is still under investigation as shown in Figure 40 on the right. Similarly, the directivity comparison of Fig. 40 left shows consistency within 0.5 dB OASPL, providing confidence for consistency in further HWB testing”²⁴.

Conclusions

The Compact Jet Engine Simulator is a viable tool for studying integrated aircraft-engine acoustics and propulsion integration effects on scaled models in a wind tunnel. The difficulty of the effort to develop the CJES into a working system was compounded by a very tight schedule. Initially the schedule had 20 months for refinement, but the contractor delivery of the CJES units was 18 months late. Fortunately the tunnel entry date also slipped. We achieved first ignition of the burner May 29, 2012 and delivered the units to the wind tunnel December 10, 2012. The control valve units had to be installed before the model support cart. The CJES units ran in the HWB test in February of 2013.

A large effort by a team was required to go from first light to test ready hardware. In the process manufacturing techniques were invented, unproductive lines dropped, alternate solutions were found, and unexpected combustion instability overcome. This work highlights the need to have integrated engineering, fabrication and research as a team to develop new capabilities in testing at Langley Research Center.

Future Work

The capabilities of the CJES units have been barely tapped. The rapid work up to the HWB test left a wide expanse of unknowns about the combustor and the CJES workings. Funding and time will be required to continue the exploration of this new test rig. A short list of future work areas is given below

- Acoustic improvements
 - Fan Flow Conditioners
 - Core Flow Conditioners
 - Modified fan plenum
- Investigate the burner operation / development
 - Combustor uniformity (azimuthally)
 - Temperature profile uniformity (radially)
 - Hot section life cycle improvements
- Expand the operating envelope of the burner to the design goals.
- Develop a model support mast that will support propulsion airframes integration (PAI) studies.

The acoustic improvements were initially described in the results summary. Lowering the high frequency noise levels and lowering rig noise will provide higher quality sound measurements. These improvements may mean expanding the size of the unit (for larger settling chamber sizes) and building in more flow conditioner inserts in the air supply system. The additional flow conditioners could be removed if low noise testing is not needed.

Flow conditioner studies have been ongoing since wind tunnels were first built. Additional studies for acoustic treatment would benefit from the larger scale of the CJES over the SAJF rig. The combustion products increased temperature range also changes the mixing physics over low temperature air tests.

Investigating the burner operation is a rich area of research. Examining the plug-vanes and flow conditioners shows that the combustion is not uniform around the annulus as shown below in Figure 41.

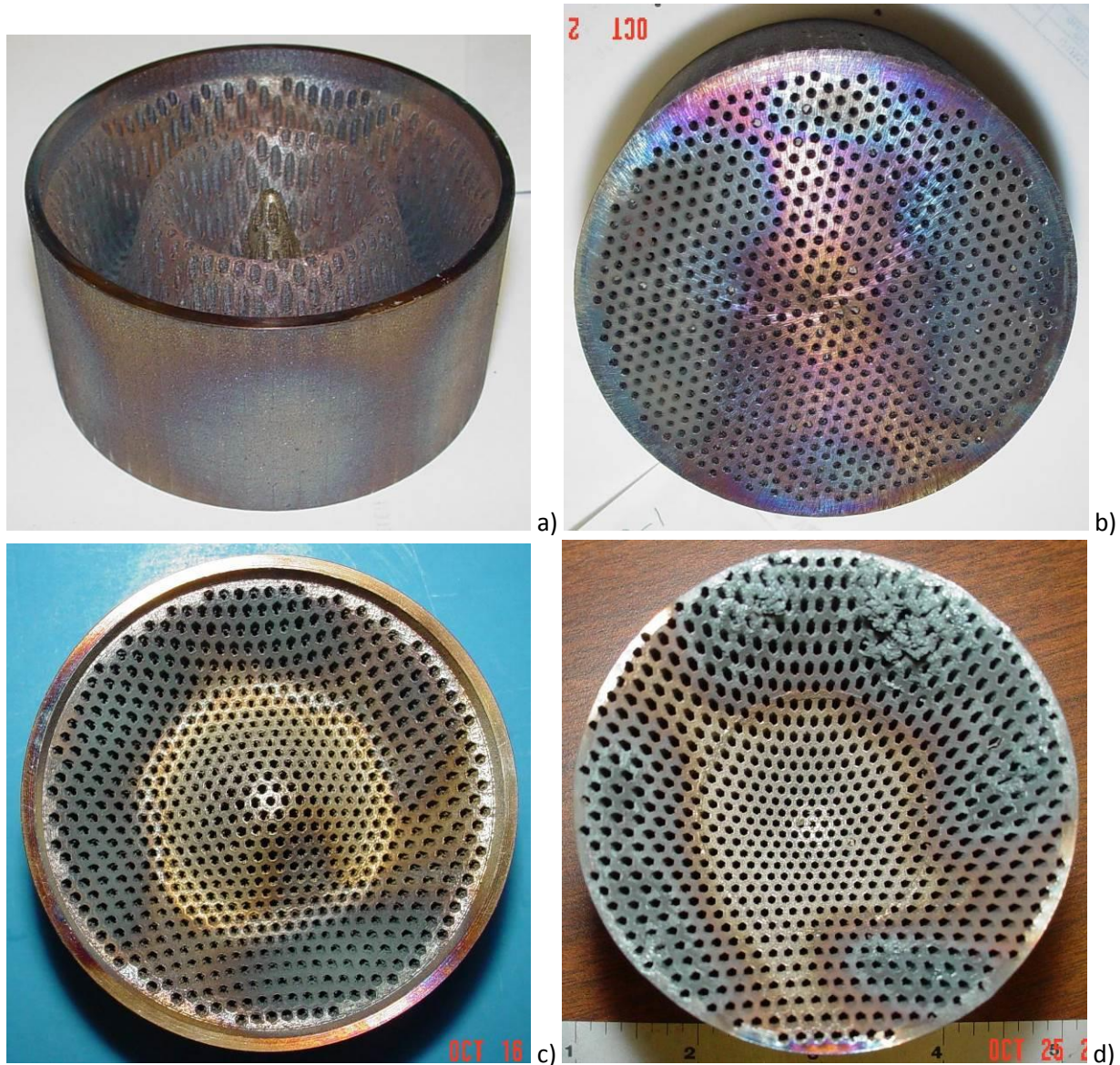

Figure 41 Core Flow Conditioners showing Nonuniform Heating. Pictures A and B show upstream and downstream view of the same part.

In Figure 41, one can see nonuniform heating oxide colors on the core flow conditioners. Note that the thickness variation of the honeycomb does not affect the patterns in pictures b) and d). Both flow conditioners have a 'Y' shaped low temperature pattern. The top section of picture D had burnt metal, a thumb nail could crush the stainless steel into flakes. That same 'Y' pattern is not quite so obvious in picture c). What is the cause of the combustion nonuniformities around the combustor? The first stage of combustor investigation would be to instrument the propane plenum with pressure taps and

measure the pressure uniformity around the manifold. The same would be done with the swirl air manifold.

Another useful tool to investigate the combustor would be to modify the core inlet plenum to add a window on the burner axis See Figure 42. This would allow one to observe the fluence of combustion with the back pressuring devices in place. Direct infrared measurements could be made along with high speed video of the flame motion.

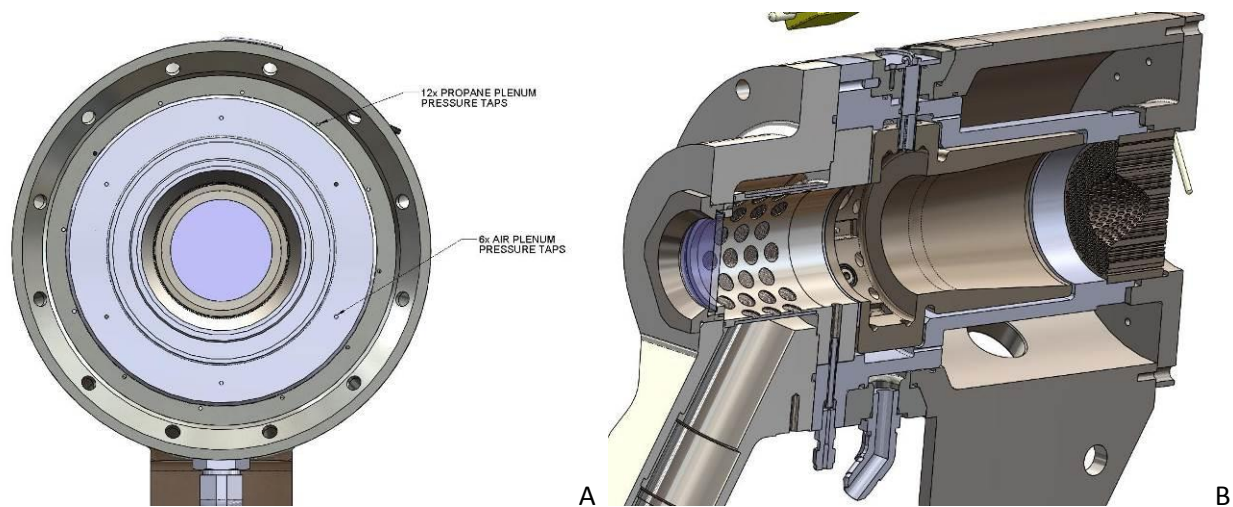

Figure 42 Combustor Modified for Pressure Taps and Axial View with a Flow Conditioner.

With those modifications one could retune the combustor and improve the combustion stability and temperature uniformity. Expansion of the burner operation up to the design point of 1.25 lbm/sec and 1150°F would be the next step. Discussions with the Advanced Measurement and Data Systems branch indicate that it is possible to perform Particle Image Velocimetry and OH fluorescence tests in a highly modified combustor. The basic combustor studies would require \$250K. The advanced imaging studies would need on the order of a million dollars.

Propulsion Airframe Integration (PAI) is becoming a crucial part of developing a new aircraft design. The interaction of the engine flow with the wings and fuselage is complex and the current Computational

Fluid Dynamics (CFD) tools can show trends but not exact enough answers to build an aircraft without verification. The CJES units can do that validation of the analysis. A model support is needed with enough flexibility to mount different models and then vary the position of the CJES units with respect to the model to study the interactions. This effort will take another large project for funding. A rough order of magnitude estimate would be four to five million dollars for a post mounted on model cart #1. If a new model cart was included, add another ten million dollars. That would result in a world class facility for PAI studies.

BIBLIOGRAPHY

- 1) Mattingly, Jack, D.; Heiser, William H.; Daley Daniel H. "Aircraft Engine Design" AIAA Education Series, 1987
- 2) Edited by Oates Gordon C "Aircraft Propulsion Systems Technology and Design" AIAA Education Series, 1989
- 3) US Patent 3,074,469, Sudden Expansion Burner Having Step Fuel Injection. January , 1963
- 4) Stull, F.D., Craig, R.R., Hojnacki J.T.; "Dump Combustor Parametric Investigation" AFAPL-TR-74-90, AF Aero Propulsion Laboratory (RJT) Wright-Patterson AFB, Ohio, 1974
- 5) Barclay Lewis P. Capt. USAF, "Pressure Losses in Dump Combustors" AFAPL-TR-72-57, AF Aero Propulsion Laboratory (RJT) Wright-Patterson AFB, Ohio, 1972
- 6) Stull, F.D., Craig, R.R.; "Investigation of Dump Combustors" AFAPL-TR-76-15, AF Aero Propulsion Laboratory (RJT) Wright-Patterson AFB, Ohio, 1976
- 7) Drewry James E.; "Characterization of Sudden-Expansion Dump Combustor Flow Fields", AFAPL-76-52, AF Aero Propulsion Laboratory (RJT) Wright-Patterson AFB, Ohio, 1976
- 8) Craig R.R., Buckley P.L., Stull F.D.; "Large Scale Low Pressure Dump Combustor Performance", AFAPL-TR-76-53, AF Aero Propulsion Laboratory (RJT) Wright-Patterson AFB, Ohio, 1976
- 9) Schmotolocha Stephen N.; "Experimental Investigation of Ignition, Combustion and Stability Characteristics of a Coaxial Sudden Expansion Burner", AFOSR-TR-1603 AD787879 Prepared by General Applied Science Laboratories, INC. for Air Force Office of Scientific Research, Arlington VA, 1974
- 10) Davis D.L., "Coaxial Dump Ramjet Combustor Combustion Instabilities Part I- Parametric Test Data", AFWAL-TR-81-2047
- 11) Lewis George D.; "Swirling Flow Combustion – Fundamentals and Application" AIAA Paper 73-1250. AIAA / SAE 9'th Propulsion Conference, 1973
- 12) Lewis George D., Smith Clifford E.; "Investigation of Centrifugal Force and Reynolds Number Effects on Combustion Processes", AFOSR-TR-75-1167, Pratt & Whitney Aircraft/United Technologies CORP. for Air Force Office of Scientific Research /NA. 1975
- 13) Lewis George D., "Combustion in a Centrifugal-Force Field", 13'th Symposium (International) on Combustion, Vol 13, Issue 1, 1971, Pgs. 625-629
- 14) Lewis George D., "Centrifugal-Force Effects on Combustion", 14'th Symposium (International) on Combustion, Vol 14, Issue 1, 1973, Pgs. 413-419
- 15) Shouse Dale T., "Trapped Vortex Combustion Technology", MITE Workshop, December 4-5, 2000

- 16) Quaale, Ryan J. Captain, USAF, "Experimental Results for a High Swirl, Ultra Compact Combustor for Gas Turbine Engines", AFIT/GAE/ENY/03-5, Air Force Institute of Technology, Wright-Patterson Air Force Base, Ohio
- 17) Zelina, Joseph, Sturgess, G. J., Shouse, Dale T., "The Behavior of an Ultra-Compact Combustor (UCC) Based on Centrifugally Enhanced Turbulent Burning Rates", 40'th AIAA/ASME/SAE/ASEE Joint Propulsion Conference and Exhibit, 11-14 July, Fort Lauderdale FL. AIAA 2004-3541
- 18) Kinzie Kevin W., Henderson Brenda S., Haskin Harry H., "Aeroacoustic Characteristics of Model Jet Test Facility Flow Conditioners", 11th AIAA/CEAS Aeroacoustics Conference (26th AIAA Aeroacoustics Conference) 23 - 25 May 2005, Monterey, California, AIAA 2005-3055
- 19) Doty, Michael J., Haskin, Henry H., "Investigation of Flow Conditioners for Compact Jet Engine Simulator Rig Noise Reduction". 17'th AIAA/CEAS Aeroacoustics Conference, 05-08 June 2011, Portland OR. AIAA 2011-2791
- 20) Anisko Jonathan, 2nd LT, USAF, "Numerical Investigation of Cavity-Vane Interactions Within the Ultra Compact Combustor", AFIT/GAE/ENY/06-M, 01, Air Force Institute of Technology, Wright-Patterson Air Force Base, Ohio
- 21) Zelina Joseph, Greenwood R. T., Shouse D. T., "Operability and Efficiency Performance of Ultra-Compact, High Gravity (g) Combustor Concepts", Proceedings of ASME TURBO EXPO '06 51TH ASME International Gas Turbine and Aeroengine Congress and Exposition, May 2006, Barcelona Spain, GT2006-90119
- 22) Thornburg Hugh, Mississippi State University; Sekar Balu, Zelina Joseph, Greenwood Roger, US AFRL, Propulsion Directorate, Turbine Engine Division, Wright-Patterson AFB, OH, "Effect of Curved Radial Vane Cavity Arrangements on Predicted Inter-Turbine Burner Performance", HPCMP USERS GROUP CONFERENCE 2007 (HPCMP-UGC 2007) 0-7695-3088-05/07 © 2007 IEEE
- 23) Zelina Joseph, Shouse Dale T., Neuroth Craig, Air Force Research Laboratory, WPAFB, Ohio, 45433, "High-Pressure Tests of a High-g, Ultra-Compact Combustor", 41st AIAA/ASME/SAE/ASEE Joint Propulsion Conference & Exhibit, 10 - 13 July 2005, Tucson, Arizona, AIAA 2005-3779
- 24) Doty, Michael J., Haskin, Henry H., "Acoustic Characterization of Compact Jet Engine Simulator Units", 19th AIAA/CEAS Aeroacoustics Conference May 27-29, 2013, Berlin, Germany, AIAA 2013-2035
- 25) Doty, Michael J., Haskin, Henry H., "Ultra-Compact Combustor Shakedown Testing in Preparation for HWB Acoustic Test", Acoustics Technical Working Group Meeting, October 23, 2012, NASA Langley Research Center, Hampton VA
- 26) Eisinger, F. L., and Sullivan, R. E., "Avoiding Thermoacoustic Vibrations in Burner/Furnace Systems," *Transactions of the ASME*, Vol. 124, November 2002, pp. 418-424.
- 27) Stephanie L Stephanie L. Heath, Thomas Brooks, Florence Hutcheson, Michael J. Doty, Henry H. Haskin, Taylor Spalt, Christopher Bahr, Casey Burley, Scott Bartram, William Humphreys, Charles B. Lunsford, Thomas Popernack and Scott Colbert, *NASA Langley Research Center, Hampton, VA, 23681*, Danny Hoad, Lawrence Becker and Daniel Stead, *Northrop Grumman*, Dennis Kuchta and

Les Yeh, *Jacobs Sverdrup ROME, NASA Langley Research Center, Hampton, VA, 23681*, "Hybrid Wing Body Aircraft Acoustic Test Preparations and Facility Upgrades", 28th AIAA Aerodynamic Measurement Technology, Ground Testing, and Flight Testing Conference, 24 - 27 June 2013, San Diego, California, AIAA 2013-2623

- 28) Collier, Fayette, Thomas Russell, Burley Casey, Nickol Craig, Lee Chi-Ming, Tong Michael, "Environmentally Responsible Aviation –Real Solutions For Environmental Challenges Facing Aviation", ICASE 2010, 27th International Congress of the Aeronautical Sciences
- 29) Collier, Fayette, "Overview of NASA's Environmentally Responsible Aviation (ERA) Project", 48th AIAA Aerospace Sciences Meeting, January 4, 2010
- 30) Heath Stephanie L., Brooks Thomas, Hutcheson Florence, Doty Michael J., Haskin Henry H., Spalt Taylor, Bahr Christopher, Burley Casey, Bartram Scott, Humphreys William, Lunsford Charles B., Popernack Thomas, Colbert Scott, Hoad Danny, Becker Lawrence, Stead Daniel, Kuchta Dennis, Yeh Les, "Hybrid Wing Body Aircraft Acoustic Test Preparations and Facility Upgrades", 28th AIAA Aerodynamic Measurement Technology, Ground Testing, and Flight Testing Conference, San Diego, CA, June 24-27, 2013, AIAA 2013-2623
- 31) Kawai Ron, Brown Derrell, Boeing Phantom Works; Spakovsky Zoltan, MIT; Papamoschou Dimitri, UCI, "Acoustic Prediction Methodology and Test Validation for an Efficient Low-Noise Hybrid Wing Body Subsonic Transport", NASA Contract No. NNL07AA54C, Final Report September 2008
- 32) Gatlin Gregory M., Vicroy Dan D., Carter Melissa B., "Experimental Investigation of the Low-Speed Aerodynamic Characteristics of a 5.8-Percent Scale Hybrid Wing Body Configuration", 30th AIAA Applied Aerodynamics Conference, June 25-28 2012, New Orleans LA, AIAA-2012-2669.

Appendix A Variations of the CJES and HWB During Development

The roots of the Compact Jet Engine Simulator go back to the original Jet Engine Simulator in the NASA Langley Research Center's Jet Noise Lab (JNL). The Author worked with Jack Seiner (Principal Investigator) and the team at Boeing's Low Speed Aeroacoustic Facility (LSAF). The LSAF had a dual stream coannular rig in their facility that Dr. Seiner wanted to beat. The Boeing design used General Electric J79 jet engine burner cans to heat the air for engine simulation. The disadvantages were nonuniform temperature and pressure profiles in the flow streams leading to the test nozzles and a temperature limit of 1500°F. Above that temperature the burner cans began rapid oxidation of the Hastalloy-X material and burner failure. The JNL wanted to reach afterburner temperatures of 3000°F. The lab had a water cooled Sudden Expansion Burner (SUE) from Marquardt Company. The concept was to use two burners, one for each stream, and build up a coaxial flow rig. The goal was to build a rig that could provide 20 pounds per second at 2000°F per stream. The water cooled SUE burners could provide 3000°F capability, but the uncooled nozzle hardware could only survive below 2000°F. This design was completed in 1994 and brought into service. It has been in service for 22 years with out a major failure. The general arrangement is shown in Figure A-1.

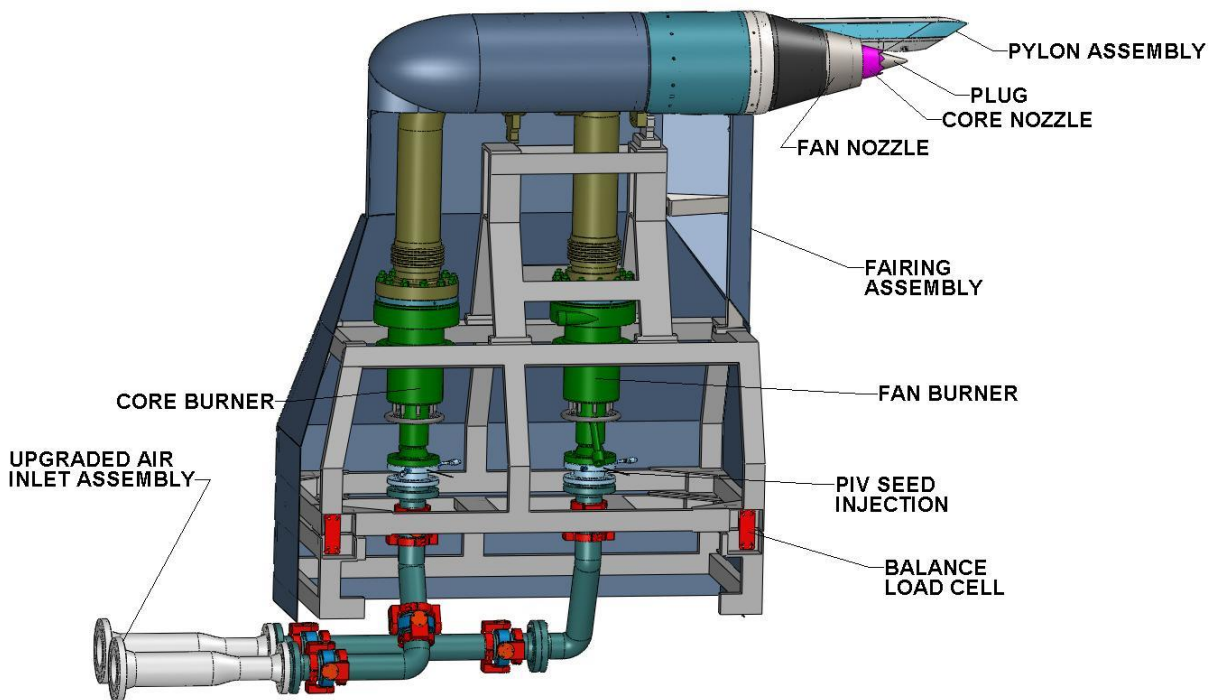
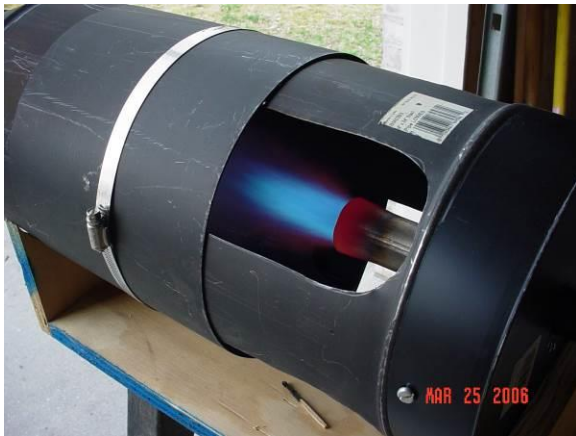

Figure A-1 Jet Engine Simulator in Subsonic Transport Engine Configuration.

The JES rig brought a spin-off customer to Langley in August of 2005. An aerospace convention with an acoustics session caught the attention of a Navy commander. A JNL paper on Fluidic Chevrons described the lab's test rig as a jet engine simulator. The Navy was looking for infrared target source to develop new seeker heads and wanted to procure six units. After several phone calls, the correct scale of their project was determined and a collaboration was begun. The end result used modified off-the-shelf propane torches to meet their requirements. The original burner is shown in Figure A-2 and the final configuration is shown in Figure A-3



A) Commercial Off the Shelf Torch



B) Torch in a NAVSEA Project Mock-up

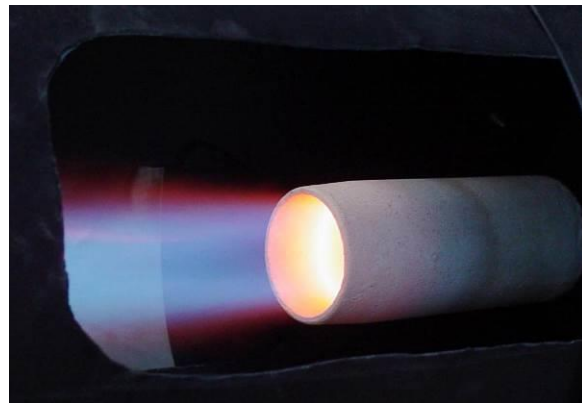

C) Ceramic Flame Holder

Figure A-2 Navy Spin-Off Burner Project.



Figure A-3 NAVSEA Jet Engine Simulator- Infrared JES-IR Final Configuration.

The initial design effort was completed in 2007 and the first generation hardware built in 2008. The systems have been in operation since 2011.

The Compact Jet Engine Simulator concept started in early 2008. The initial design was a simple premixed combustor. Then that changed to a dump combustor with fuel injection just upstream of the step⁽⁴⁾. The next attempt to increase flame speed was turbulence generators, then swirl vanes. By the end of the year, the literature review made it clear that a dump combustor was not going to meet the short overall length requirement. The fully turbulent flame speeds of 20-100 ft./sec would need 9 feet of travel length to not impinge on the flow conditioners and rakes. The CJES design had less than 8 inches from fuel injection to the rakes. The Air Force Research Lab's Ultra Compact Combustor was the solution. That combustor was simpler to build than the more advanced trapped vortex combustors and would meet our requirements. In Figure A-3 one can see the progression of the design with time. The

bent versions were needed while Boeing was iterating on the airframe design. The closer the nacelle is to the surface the lower the overall drag, but the surface flow over the wing-body caused flow separation at the engine inlet producing engine stall. Later airframe versions corrected for supersonic flow between the nacelle and body with the resultant shocks. In the end, the design needed less runway and had a larger cargo capacity and range than the initial requirements called for.

Figure A-6 shows the podded twin engine concept that was the final configuration for the Environmentally Responsible Aviation study. Figure A-7 shows the embedded engine configuration. This configuration has the potential to be even more efficient, but ingesting the boundary layer into the engine had more technical issues than could be solved for a 2025 operational aircraft, so that concept was dropped.

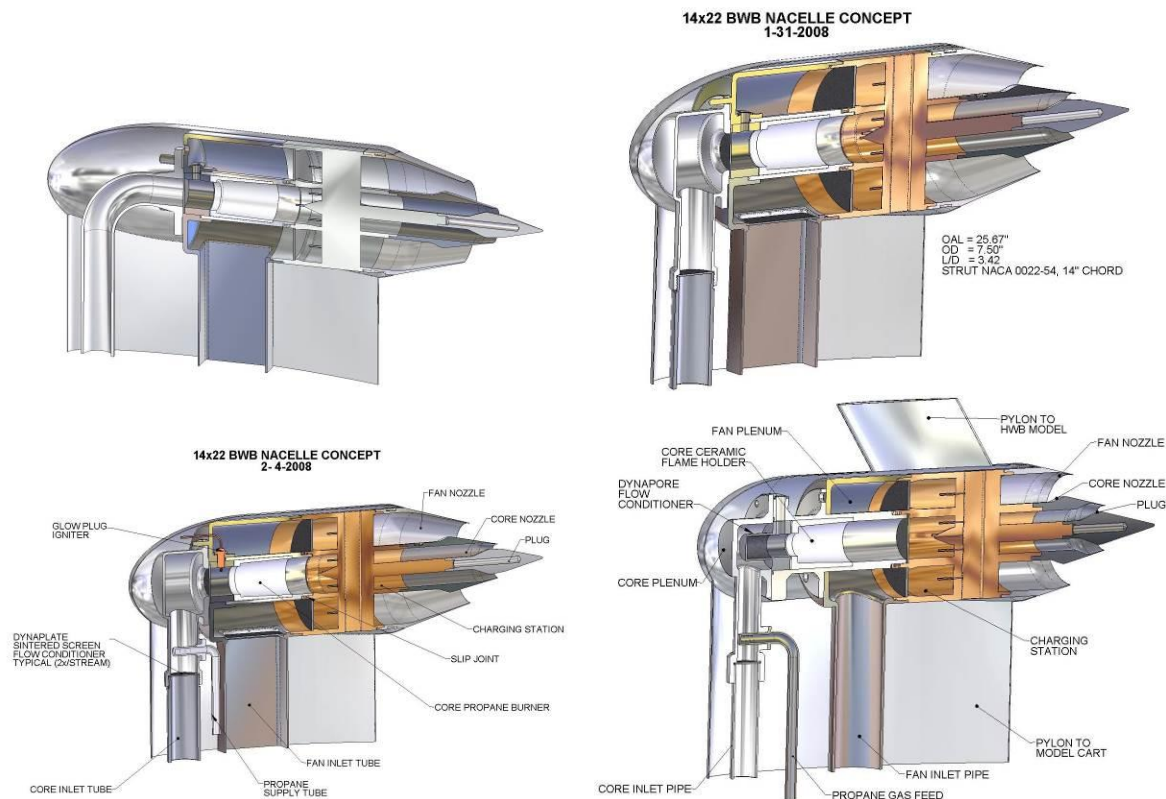

JET ENGINE SIMULATOR CONCEPT
JNL-015-08-F

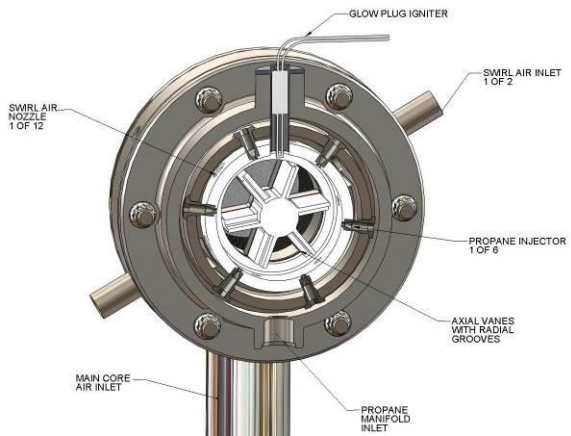
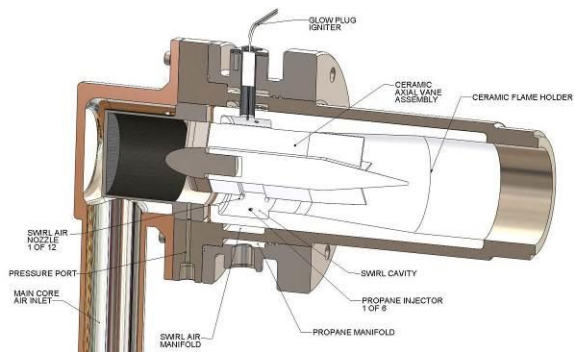
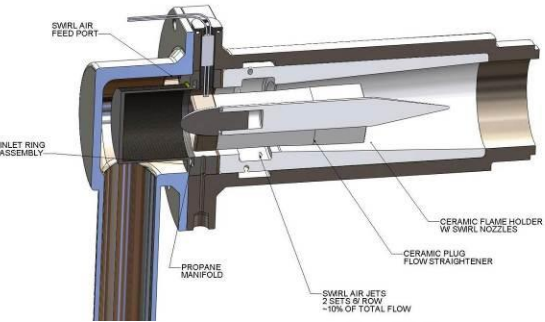
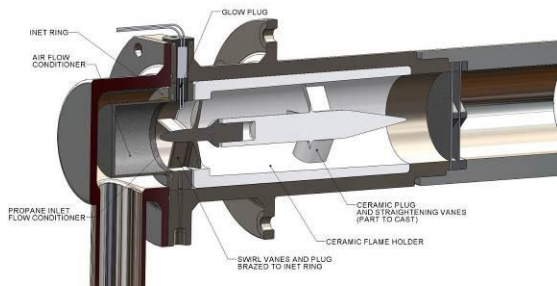
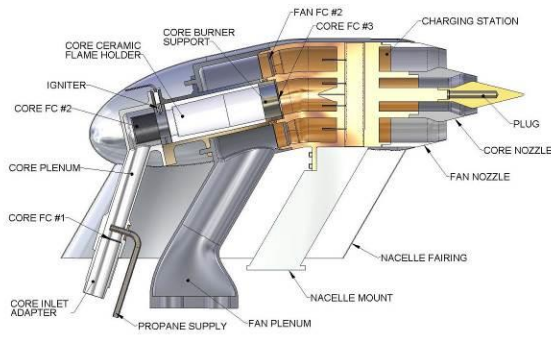
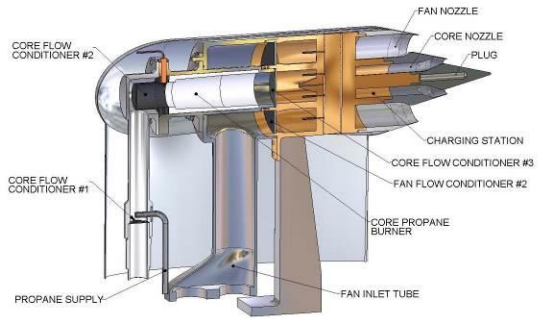

JET ENGINE SIMULATOR CONCEPT
JNL-015-08-G

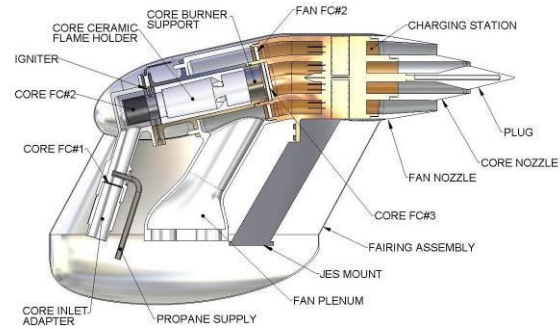
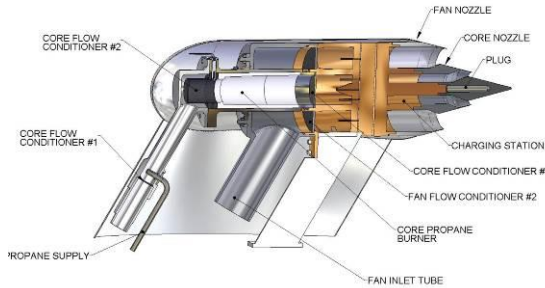

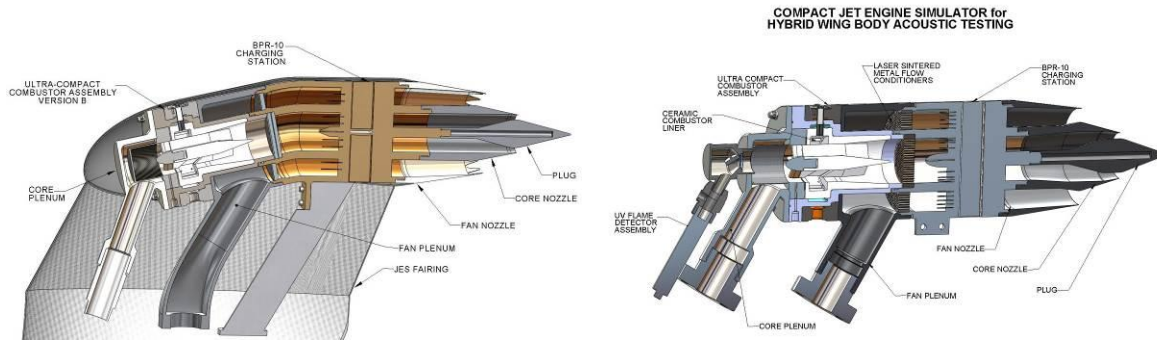

Figure A-4 Compact Jet Engine Simulator Variations before Detail Design Contract

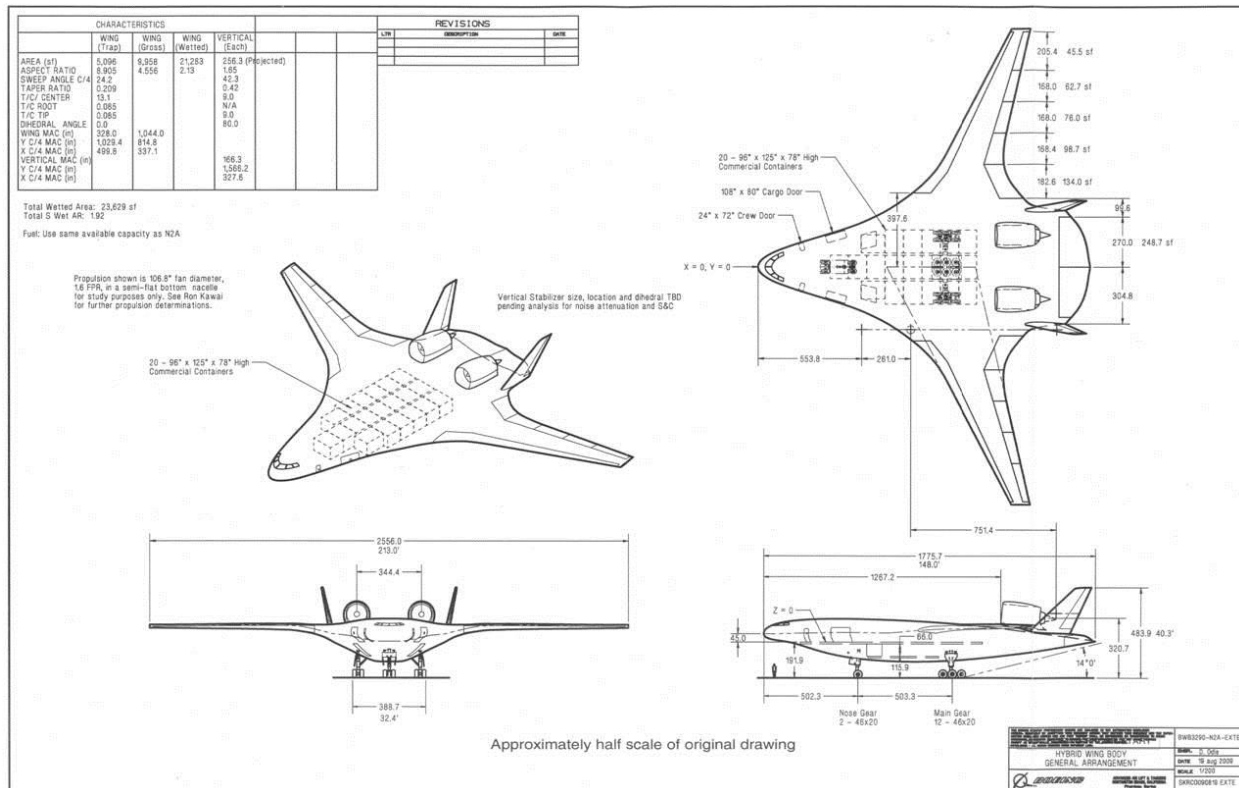

Figure A-5 Boeing N2A-EXT Aircraft Concept, NASA Contract Number NNL07AA54C⁽³¹⁾

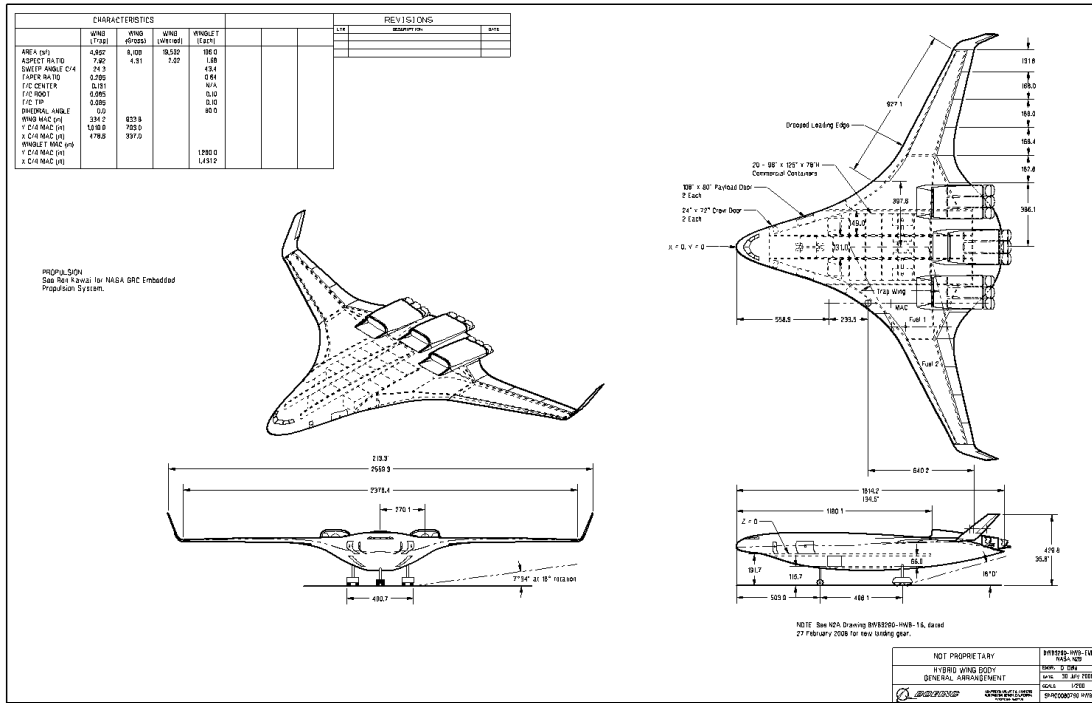

Figure A-6 Boeing N2B Aircraft Concept, NASA Contract Number NNL07AA54C⁽³¹⁾

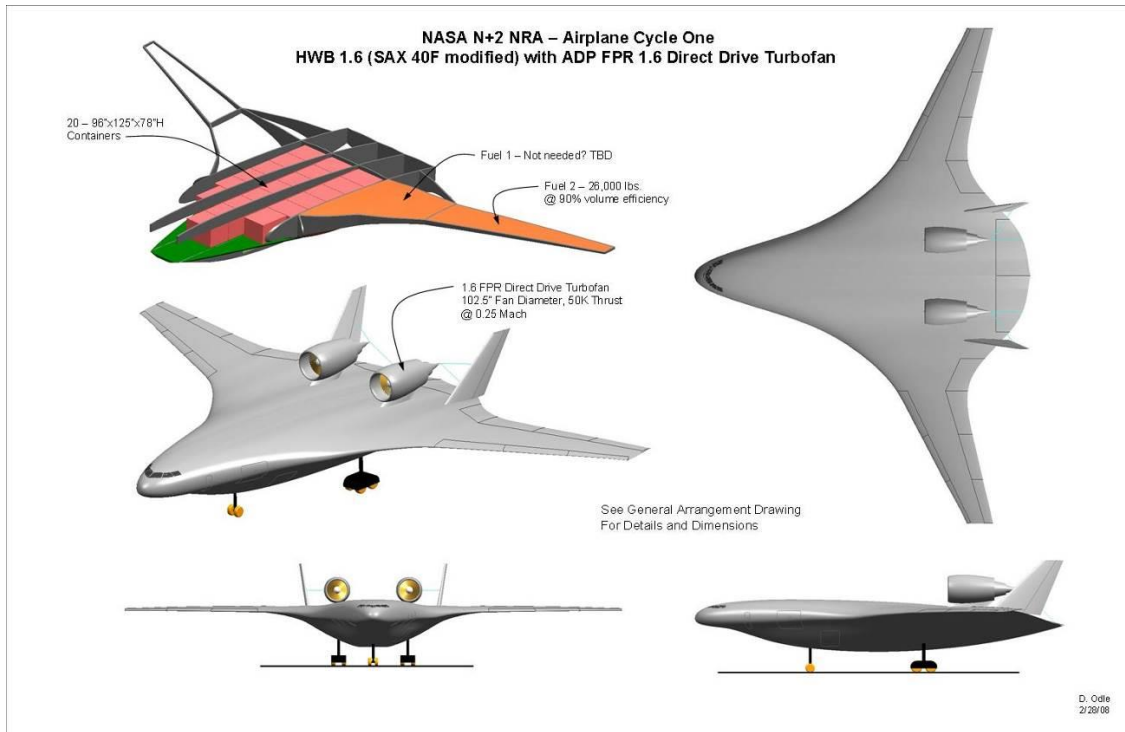

Figure A-7 Boeing N2A Cargo Configuration⁽³¹⁾

Figure A-7 shows the cargo layout of the podded engine configuration. The design study showed that the outer wing tanks were all that was needed for a 6000 NM range, the inboard tanks (upper left image) were dropped. The ERA project was in the headlines of the aviation industry, Aviation Week had several articles on the project. Aerospace Testing International 2010 Showcase had an article that included CAD images from the Author.

Appendix B Infrastructure to Support HWB Acoustic Test

The Validation Test Project at NASA Langley to support the ERA project involved a massive effort to build an infrastructure to allow the test to occur. The wind tunnel had never tested with combustion in the facility, the phased array instrument was twice the size of previous versions, the tunnel needed a traverse system to position all of the microphones and more. Figure B-1 shows the major subprojects that all formed the final test.

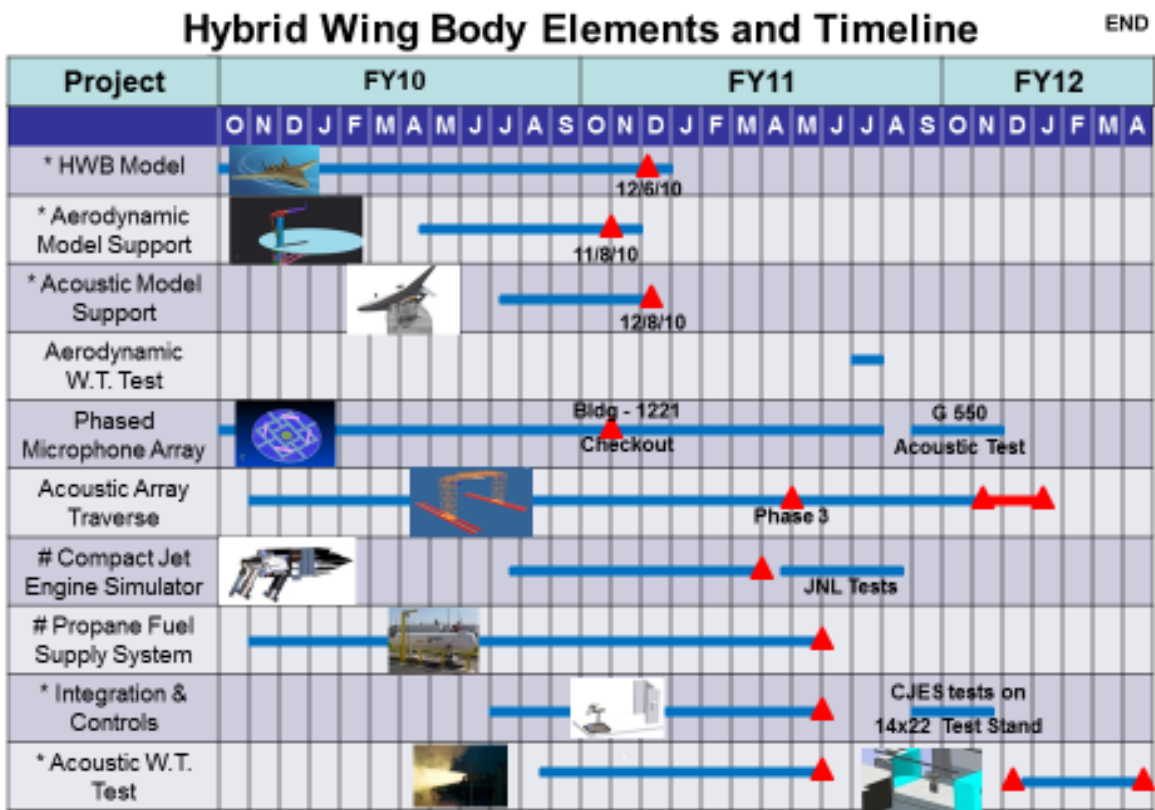

Figure B-1 Work Breakdown Structure for HWB Test Preparations. * Author Supported, # Author Team Lead

One of the major selling points in the plan to test in the 14x22' Subsonic Wind Tunnel was the risk reduction efforts at the Jet Noise Laboratory to develop the Compact Jet Engine Simulator, the controls,

operating program, procedures and verify all of the safety interlocks before entering the 14x22' tunnel. In addition, once the system was running the JNL provided operator training and certification prior to operations in the 14x22' Tunnel. Operations in the JNL cost \$4000/day and operations in the 14x22' tunnel cost \$20,000/hour, this supplied a great cost savings to the program. The CJES control system was a single rack for each unit. Figure B-2 shows one of the racks in the NJL control room. The fuel control valves were pallet mounted as shown in Figure 20. This allows for each unit to operate independently if the test calls for only one unit.



Figure B-2 LSAWT Control Room, CJES standalone console on the left.

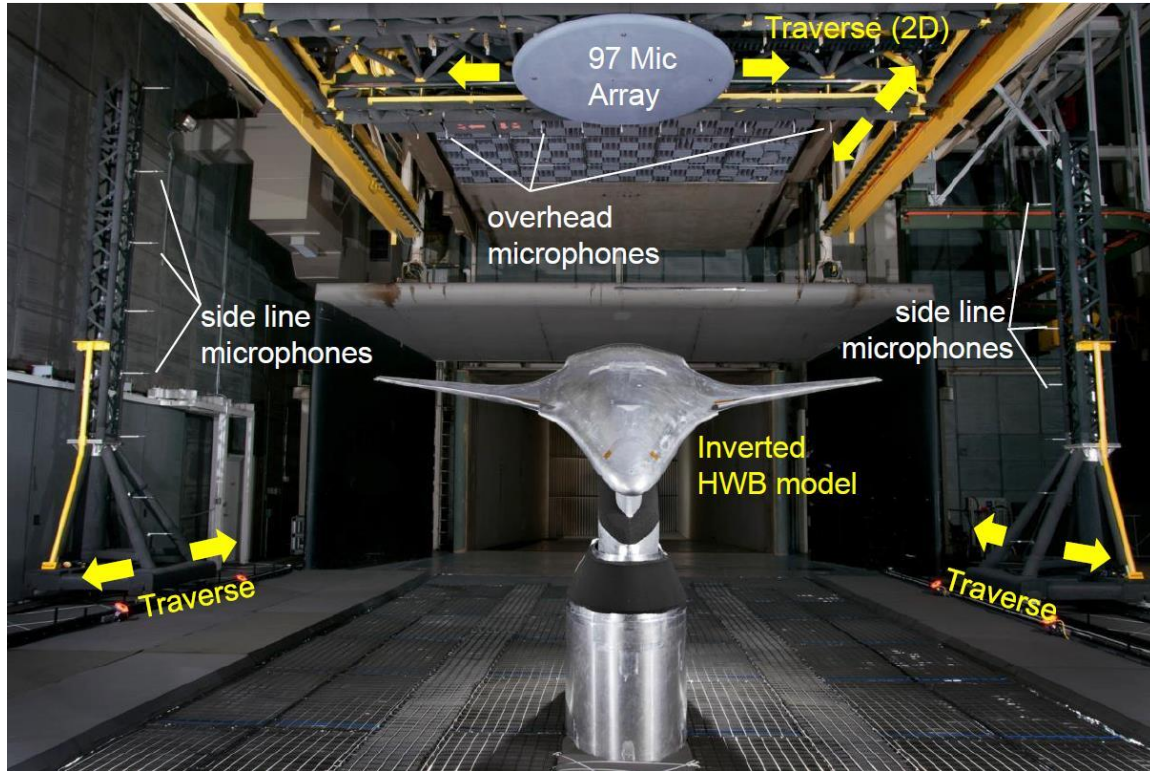

Figure B-3 Acoustic Validation Test in the 14x22' Subsonic Wind Tunnel, Microphone Configuration⁽³⁰⁾.

The wind tunnel required new acoustic treatment on the floor and walls. The old material (15-20 years old) had broken down over time. Figure B-3 shows the 34 sideline and overhead microphones along with the 97 microphone phased array. The phased array can after processing locate noise sources from the model. Airframe sources such as flap edges are generated by vorticity from flap edges and are close to point sources. Jet noise on the other hand is a distributed source (from 5-10 diameters long) smeared downstream along the jet plume. The processing program can isolate the multiple sources and reject wind tunnel noise as well. Figure B-4 shows the HWB model with the CJES units installed.

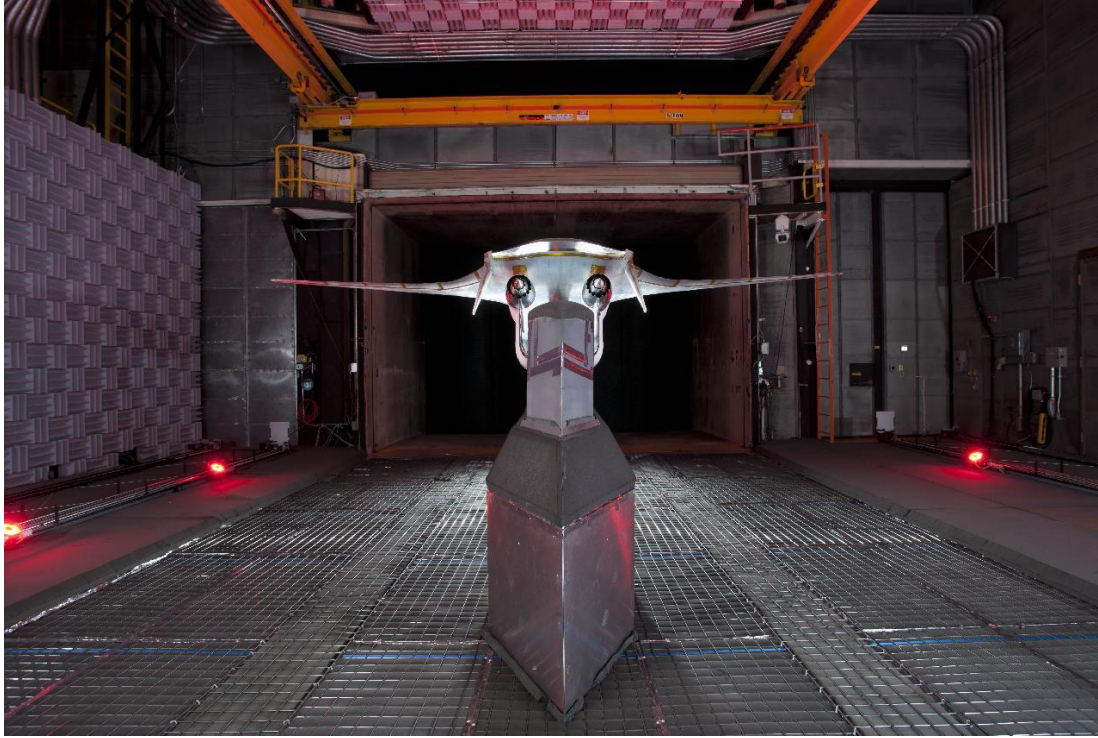

Figure B-4 Aft View of the Hybrid Wing Body Showing the CJES Units⁽³⁰⁾

Before the acoustic testing could be done, an aerodynamic test was completed to obtain the performance of the isolated airframe. From the static pressure tap information over the model surface we could adjust the acoustic model's orientation (pitch, yaw and roll) to match the aerodynamic test results and compensate for the CJES hardware. Figure B-5 shows the aerodynamic test in the 14x22' tunnel. In addition to force, moment and pressure data, oil flow was used to map the surface flow direction over the HWB. Figure B-6 shows the oil flow result with the leading edge flap and trailing edge flaps deployed. Earlier CFD results predicted that the inboard leading edge flap end vortex would either be sucked into the engine or hit the vertical tail. The first result would stall the engine at takeoff and the second would cause a loss of control authority for the tail. The leading edge flap inboard edge was moved outboard to eliminate the problem.



Figure B-5 Aerodynamic Test of the HWB in the 14x22' Subsonic Wind Tunnel⁽³²⁾



Figure B-6 Oil Flow Visualization of Surface Flow Patterns⁽³²⁾**VITA**

Henry H. Haskin
 957 Heathland DR.
 Newport News, VA 23602
 Work Phone: 757-864-6939
 Home Phone: 757-813-5171

email: henry.h.haskin@nasa.gov
hask002@odu.edu

Education:

Old Dominion University
 Mechanical & Aerospace Engineering
 238 Kaufman Hall
 Norfolk, VA 23529
 Master of Science in Aerospace Engineering 2016

Virginia Polytechnic Institute and State University
 Bachelor of Science in Mechanical Engineering 1979

Work Experience:

NASA, Langley Research Center 1990-present
 Aeroacoustics Branch, Research Directorate 1996-present
 12B Langley Boulevard, Hampton VA 23681-2199
 Jet Noise Laboratory, Facility Engineer/Safety Head

Facilities Engineering Branch, Facilities Systems Engineering Division 1990 to 1996
 1 North Dryden Street, Hampton VA 23681
 Project Manager

Planning Research Corp 1998 to 1990
 303 Butler Farm Road, Hampton, VA 23666
 Project Engineer

MicroCraft Inc. 1985 to 1989
 3130 North Armistead Avenue, Hampton VA 23666
 Project Engineer

Engineering Incorporated 1981 to 1985
 41 Research Drive, Hampton VA 23666
 Project Engineer

Goodyear Tire & Rubber Co 1979 to 1981

1144 Market Street Akron, Ohio 44316
Machine Designer